

EM

The Best

THE WORLD HAS TO OFFER

EM> ELECTRIC MIRROR®





Manhattan Skyline
New York, New York

Contents

INTRODUCTION

- 6** Our Company
- 12** Our Commitment
- 24** Our Clients
- 50** Our Capabilities
- 60** Our Value

TECHNOLOGY

- 76** Keen
- 78** Ava
- 80** Vive
- 82** Poet
- 84** Seamless
- 86** Polaris
- 88** Televisions
- 90** Hospitality TV

PRODUCTS

- 94** Lighted Mirrors
- 132** Polycarbonate Mirrors
- 140** Mirror TVs
- 156** TV Covers
- 160** Mirrored Cabinets
- 168** Makeup Mirrors
- 186** Wardrobe Mirrors
- 192** Fog-Free Mirrors
- 198** Corridor Lighting
- 206** Framed Mirrors
- 210** UVC Disinfection
- 220** New Products

INFORMATION

- 242** Client Project Credits
- 244** Connect with Us

Introduction



CONTENTS

6	Our Company
12	Our Commitment
24	Our Clients
50	Our Capabilities
60	Our Value



OUR COMPANY





Space Needle
Seattle, Washington

From Garage to Global

The year was 1997. Jim “Doc” Mischel, Sr., a former dentist with the heart of an inventor, was spending time working on projects in the family garage. Jim Mischel, Jr., his son, had recently earned a law degree. With a flair for innovation and a knack for business, they decided to launch a new company, and Electric Mirror was born.

That garage is where the Mischel family turned out their first innovation, a high-end defogging mirror. In those days, family and workforce were one and the same, with parents Faith and Doc, and younger brother Aaron handling everything from sales and phones to manufacturing. Younger sister Mia, though still in school, was also kept in the picture.

Electric Mirror’s innovative product lines expanded, and it wasn’t long before demand outpaced the production capacity of the Mischel family home. Through the years, the company’s rapid growth required expanding to ever-larger manufacturing facilities. As the company’s footprint grew, so too did its reputation, earning it a significant amount of publicity and recognition along the way.





"My family and I founded this company on the simple idea of offering the very best products, backed by the very best warranties, and supported by the very best team – and we've never wavered from that commitment."

- Jim Mischel, CEO



Today, Electric Mirror is the global leader in mirror and lighting technology. Its product lines have expanded to include lighted mirrors, polycarbonate mirrors, mirror TVs, TV covers, mirrored cabinets, makeup mirrors, wardrobe mirrors, and corridor lighting. Most recently, in response to the COVID pandemic, the company created a new division that uses UVC light to fight disease-causing viruses. This type of industry-leading ingenuity is evidenced by over 60 patents earned, with many other patents pending.

The company's global headquarters is in Everett, Washington, where it operates a 125,000 square foot domestic manufacturing facility that employs over 200 people. Electric Mirror also produces products through international contract manufacturing facilities.

Electric Mirror has earned a sterling reputation throughout the hospitality, commercial, healthcare, senior living, multi-family, and residential industries. Every day, millions of people across 100 countries delight in Electric Mirror products. And every day, more designers, architects, purchasers, and owners around the world are choosing Electric Mirror products - the best the world has to offer.



LEADERSHIP BY THE NUMBERS

1,500,000

People around the world who enjoy using Electric Mirror products every day

125,000

Square foot company headquarters and manufacturing facility in Everett, Washington

200

Employees dedicated to designing and building the most innovative mirror technology products on the market

100

Countries around the world where Electric Mirror products are used in hotels, commercial properties, and residences

65

Patents received for utility and design innovations, with another 50 pending

25

Industry awards recognizing Electric Mirror's leadership in product innovation and business success

10

Company departments focused on innovative leadership, including R&D, Engineering, Product Management, Quality, Manufacturing, Logistics, Sales, Marketing, Customer Service and Administration

6

Channels served, beginning in Hospitality, and growing to include Residential, Commercial, Multi-Family, Healthcare and Senior Living

1

Common vision: To lead the industry by infusing mirror and technology with inspired design that captivates our customers



OUR COMMITMENT



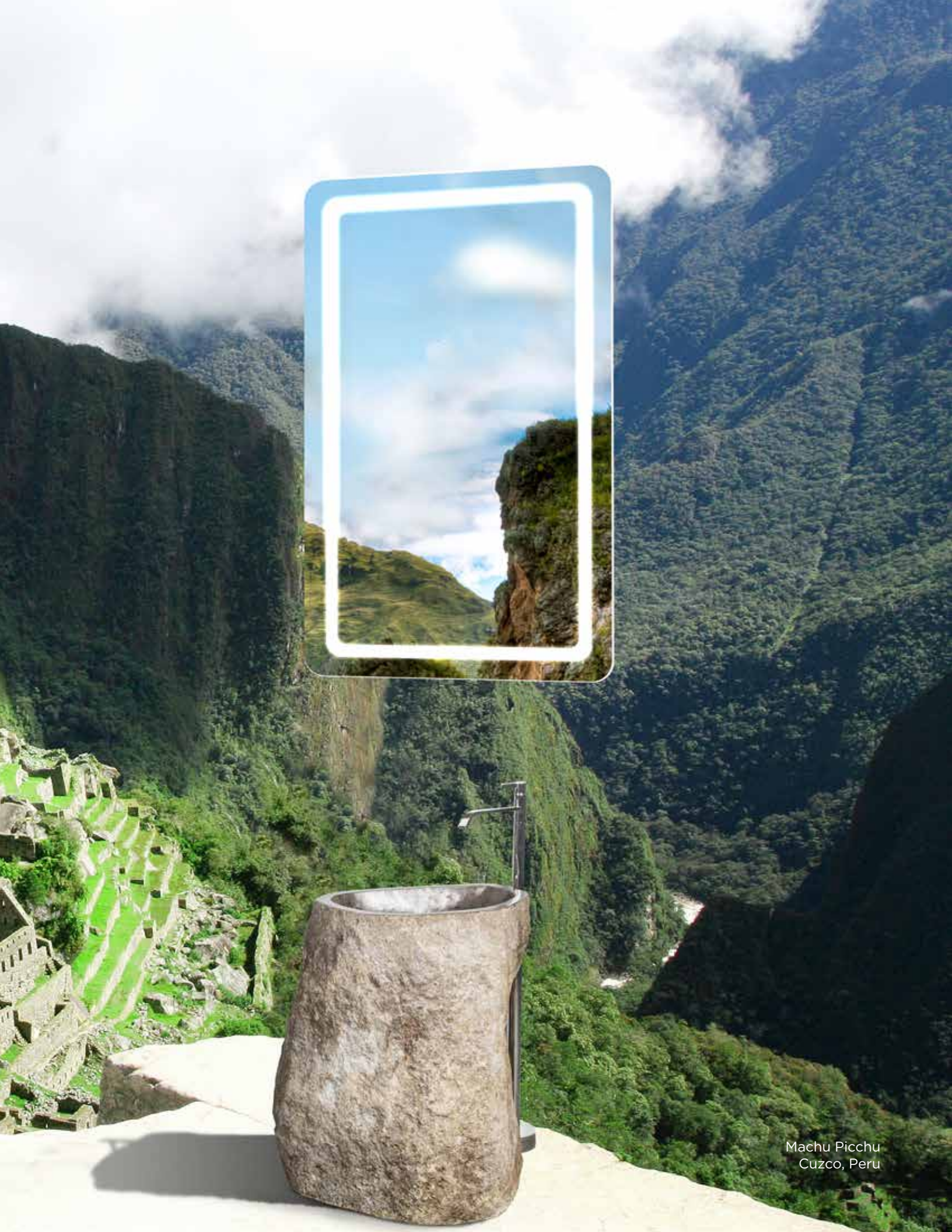

Machu Picchu
Cuzco, Peru

Exceptional Style

that combines fashion, form, and function.



Electric Mirror products are as much a fashion statement as they are a representation of flawless functionality. Here, bold design strikes a balance with intelligent technology to create a mirrored centerpiece that unites dazzling aesthetics with twenty-first century style.



Custom Eternity Lighted Mirror
Waikiki Beachcomber by Outrigger, Hawaii
SFA Design, Designer





Innovative Technology

that sets the industry standard.

As the original architect of the lighted mirror industry, innovation has always been at the forefront of everything we do. From creating the first fog-free mirror, to incorporating TVs into lighted mirrors, to creating mirrors with embedded technology, we've earned an unequivocal reputation as the industry leader in ingenuity.

Custom Mirror TV
Four Seasons, Kuwait
Yabu Pushelberg, Designer

Unparalleled Value

that safeguards your investment.

Price is temporary, but value lasts forever. That's why Electric Mirror builds the highest-quality products, and designs them to last. With Electric Mirror, you get sophisticated engineering that ensures maintenance-free operation. Mirror that won't corrode or yellow with age. And a superior warranty backed by a U.S. customer support team. Combined, it means a total cost of ownership that provides the greatest return for your investment.





Custom Silhouette Lighted Mirror
Tulalip Resort Casino, Washington
IDI Studio, Designer



Worldwide Appeal

that elevates your projects' panache.



Custom Integrity Lighted Mirror
Le Royal Monceau, Paris
Philippe Starck, Designer

Beginning in hospitality, Electric Mirror products set the stage for a superior guest experience. As our reputation grew, so too did our expansion into other markets, including commercial, healthcare, multi-family, senior living, and residential. Today, we have more installations than all others combined, and our products are in high-demand for the most esteemed projects worldwide.





Unrivaled Satisfaction

that makes your decision easy.

No other name defines leadership, style, innovation, and value quite like Electric Mirror. From the beautiful and inspiring products we create, to the quality and integrity with which they're built, our mission is to produce products that we're proud to stand behind, and that you'll be proud to feature in your next project.

Custom Eternity Lighted Mirror
Bellagio Resort, Las Vegas
The Gettys Group, Designer



OUR CLIENTS

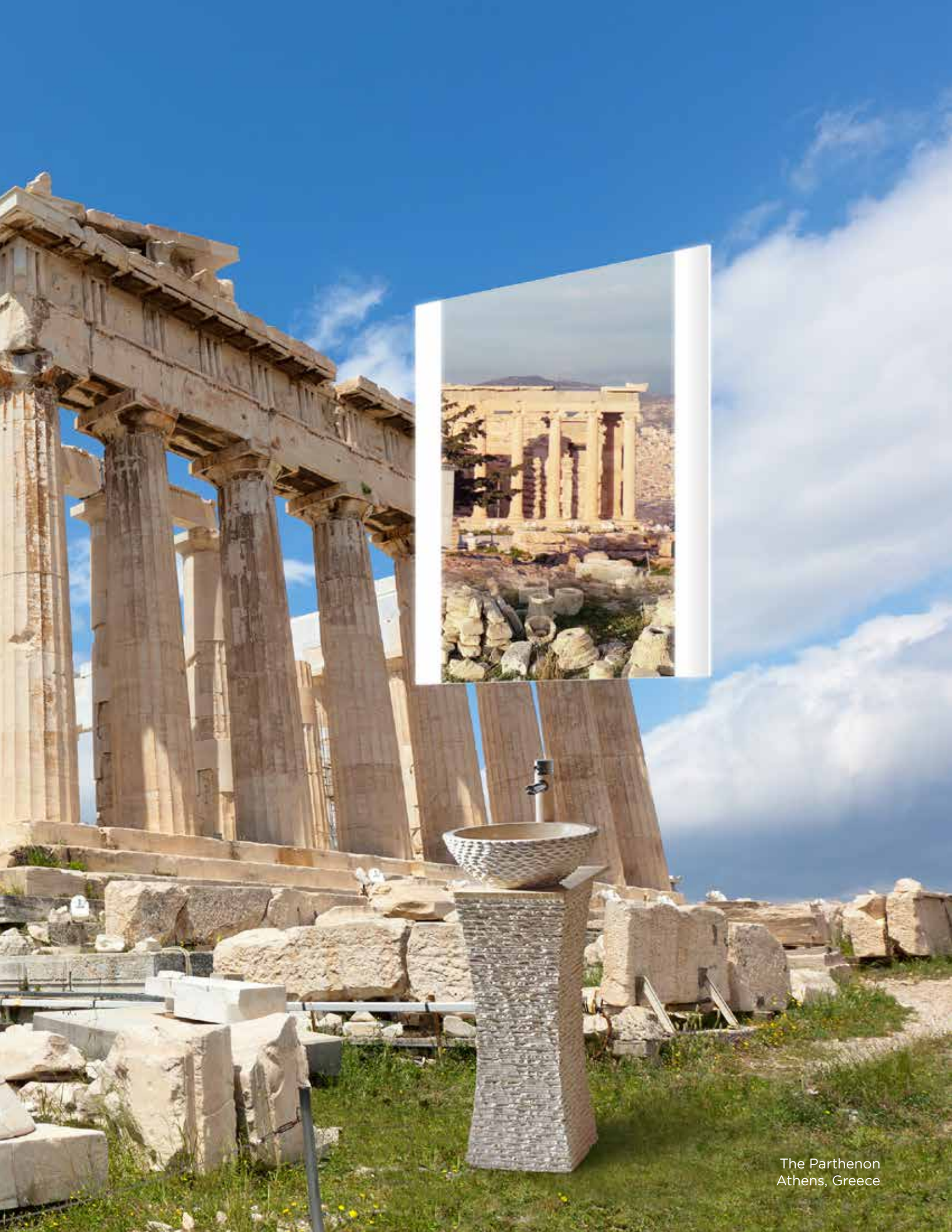

The Parthenon
Athens, Greece



Global Prestige

that affirms you're in good company.

Electric Mirror has been chosen for many of the world's most renowned and celebrated projects. From towering Middle East hotels and trendy 5th Avenue boutiques, to sleek Fortune 500 corporate offices and luxurious sporting arena owners' suites, our products are sought after by the world's leading brands.

HOSPITALITY BRANDS



COMMERCIAL BRANDS





Custom Element Lighted Mirror
Omni Boston Seaport, Boston
Waldrop + Nichols Studio, Designer



Custom Integrity Lighted Mirror
The Phoenician, Scottsdale
Wimberly Interiors, Designer

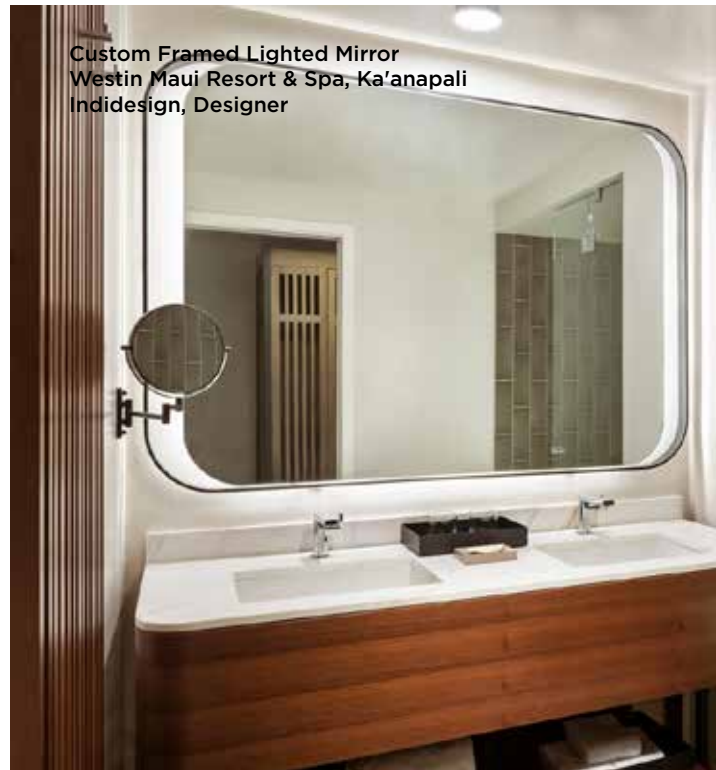

Custom Framed Lighted Mirror
Westin Maui Resort & Spa, Ka'anapali
Indidesign, Designer



Select U.S.A. Projects

Baccarat New York NY
Bahai Hotel CA
Bellagio NV
Caesar's Atlantic City NJ
Cherokee Casino NC
Chicago Marriott Downtown IL
Dallas Convention Center TX
Delano NV
Deloitte University TX
Disney Contemporary Resort FL
Doubletree Denver CO
Embassy Suites Nashville TN
Equinox Hudson Yards NY
Estancia del Norte San Antonio TX
Fairmont Kea Lani HI
Flamingo Las Vegas NV
Four Seasons Baltimore MD
Four Seasons Disney Orlando FL
Four Seasons Las Vegas NV
Four Seasons Maui HI
Four Seasons Minneapolis MN
Grand Hyatt New York NY
Grand Hyatt San Diego CA
Harrah's Atlantic City NJ
Harrah's Las Vegas NV
Hilton Americas Houston TX
Hilton Grand Islander HI
Hilton Hawaiian Village HI
Hilton Marco Island FL
Hilton Minneapolis MN
Hyatt Regency Chicago IL
Hyatt Regency Embarcadero CA
Hyatt Regency San Francisco CA
Hyatt Regency Seattle WA
Hyatt San Francisco Airport CA
JW Marriott Chicago IL
JW Marriott Essex House NY
JW Marriott Marco Island FL
Knickerbocker Hotel NY
L'Ermitage CA
Langham Chicago IL
Loews Regency NY
Loews Santa Monica CA
Loews Sapphire Resort FL
Marriott City Center Denver CO
Marriott Grand Ocean SC
Marriott Los Angeles CA
Marriott OceanWatch Resort SC
Marriott Orlando World Center FL
Metropolis Irvine CA
Montreign Resort Casino NY
Mystic Lake Casino MN
Oceanwide Tower CA
Omni Boston Seaport MA
Outrigger Reef Waikiki HI
Palazzo Westwood Village CA
Park Hyatt FL
Park Lane Hotel NY
Pinnacle Baton Rouge LA
Renaissance DC
Renaissance Indian Wells CA
Renaissance Nashville TN
Revel Hotel & Casino NJ
River City Pinnacle MO
San Francisco Marriott Marquis CA
Seaport Hotel Boston MA
Sheraton Denver CO
Sheraton New Orleans LA
Sheraton New York NY
Sheraton Seattle WA
Taj Boston MA
The Broadmoor CO
The Cliff Royal Sonesta CA
The LaSalle Chicago IL
The Phoenician AZ
The Quad Resort & Casino NV
Thunder Valley Casino CA
Trump Las Vegas NV
Tulalip Resort Casino WA
Virgin Hotels Las Vegas NV
W Marriott Washington DC
Waikiki Hyatt Beach Resort HI
Westin Chicago O'Hare IL
Westin Copley Place MA
Westin Grand Central NY
Westin Kierland AZ
Westin Los Angeles CA
Westin Maui HI
Westin Peachtree GA
Westin Seattle WA
Westin St. Francis CA
Wilshire Grand Hotel CA
Wynn Tower NV
Yotel NY



Select New York Projects

120 Ocean Drive
 35 Hudson Yards Tower
 600 West 58th Street
 Affinia Manhattan
 Ameritania Hotel
 Artezen Hotel
 Bernic Hotel
 Best Western Buffalo
 Bryant Park Towers
 Concorde Hotel
 Courtyard Syracuse
 Crosby Street Hotel
 Crowne Plaza JFK
 Delta T4 Sky Club
 Doubletree Metropolitan
 Embassy Suites
 Emerson Resort and Spa
 Equinox Hotel
 Even NYC 44th
 Eventi Hotel
 Fairfield Inn 58th Street
 Fairfield Inn Geneva
 Four Seasons 57th
 Gurney's Montauk Resort
 Hard Rock Times Square
 Henry Hudson Hotel
 Hilton Canopy
 Hilton Garden Inn Water Street
 Hilton Grand Vacation Club
 Hilton Long Island
 Hilton New York
 Hilton Times Square
 Holiday Inn Auburn
 Holiday Inn Express Brooklyn
 Holiday Inn Express LaGuardia
 Holiday Inn Rochester
 Homewood Suites Amherst
 Hotel Del Monica
 Hotel Indigo
 Hotel Roger Williams
 Howard Johnson Brooklyn
 Hyatt Place Long Island
 Hyatt Place Niagara Falls
 Intercontinental Barclay Hotel
 Iroquois Hotel
 JW Marriott Essex House
 Knickerbocker Hotel
 La Quinta Brooklyn
 Langham Place
 Le Soleil Hotel
 Lotte NY Palace Hotel
 Mandarin Oriental
 Marriott Brooklyn
 Marriott Long Island Uniondale
 Marriott Marquis
 Moët Hennessey
 Montreign Resort Casino
 Muse Hotel
 NYLO Time Hotel
 NYU Winthrop Hospital
 Park Central Hotel
 Park Hyatt
 Park Lane Hotel
 Peninsula 5th Avenue
 Portland Square Hotel
 Radisson Martinique
 Renaissance NYC West 25th Street
 Renaissance Times Square
 Residence Inn Riverhead Long Island
 Rivers Casino Schenectady
 Seneca Allegany
 Sheraton New York
 Sheraton on the Falls
 Sheraton Tarrytown
 Soho Grand Hotel
 SpringHill Suites Carle Place
 SpringHill Suites Queens Jamaica
 St. Regis Hotel State Tower
 The Alise
 The Benjamin Hotel
 The Lexington Hotel
 The Manhattan at Times Square
 The Milburn
 The Modern
 The Quin
 The Ritz Carlton Battery Park
 The Solita Hotel
 Tru-Homewood
 W Times Square
 W Union Square
 Westin Buffalo
 Westin Grand Central
 Westin Times Square
 Yotel New York





Eternity Lighted Mirror
Shelburne Hotel & Suites
DiLeonardo, Designer

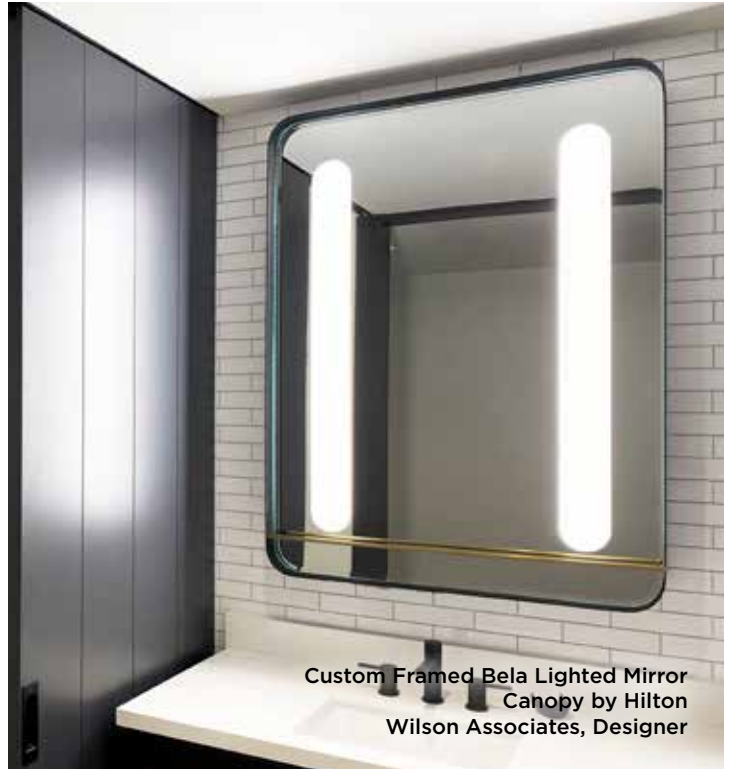

Custom Framed Bela Lighted Mirror
Canopy by Hilton
Wilson Associates, Designer



Custom Loft Mirror TV
St. Regis Hotel
HDC Interior Architecture & Design, Designer



Custom Silhouette Lighted Mirror TV
M Resort
Marnell Corrao Associates, Designer



Silhouette Lighted Mirror
Palms Casino
Avenue Interior Design, Designer



Custom Fusion Lighted Mirror
Aria
BBG-BBGM, Designer

Select Las Vegas Projects

ACH Sky Villas
Ahern Casino
American Airlines Admiral's Club
Aria Resort & Casino
Atlantis Casino
Bally's
Bellagio
Brezza Restaurant
Buena Vue Casino
Caesars Convention Center
Caesars Palace
Candlewood Suites
Circus Circus Reno
Cosmopolitan Resort & Casino
Courtyard
D Hotel
Delano
Desolation Hotel
Eldorado Resort and Casino
Eldorado Suites
Embassy Suites
Flamingo Hotel & Casino
Fontainebleau Resort Four Points
Four Seasons
Golden Nugget
Grand Canyon Apartments
Green Valley Ranch
Hampton Las Vegas
Hard Rock
Harrah's
Harrah's Mardi Gras
Hexx Restaurant
Hilton Grand Vacations Paradise
Hilton Royal Crest
Holiday Inn Express
Holiday Inn Express Elko
Holiday Inn Express Minden
Holiday Inn Express Reno
Hyatt Place Silverton
Hyatt Regency Tahoe
Illuminarium Vegas
JW Marriott
Las Vegas Arena
Las Vegas Boulevard Tower
Las Vegas Raiders Stadium
Luxor Allied Esports Arena
Mandalay Bay
Mandarin Oriental
Marriott
Marriott Grand Chateau
Metropolis
MGM Grand
MGM Grand Stay Well Rooms
MGM Mirage
Monte Carlo High Rise Park
Monte Carlo Resort & Casino
MVC Grand Chateau
New Century Plaza
Nobu Hotel at Caesars
Palazzo Chairman Suites
Palazzo Gaming
Palms Casino Resort
Palms Fantasy Tower
Peppermill Resort Casino
PH Towers Westgate
Planet Hollywood
RA Sushi
Red Rock Casino
Red Rock Resort & Spa
Renaissance
Residence Inn Reno
Rio Hotel & Casino
Riviera Hotel & Casino
Silver Legacy
Silverton Casino
Stratosphere
Tahoe Seasons Resort
Tesoro Apartments
The Linq Hotel & Casino
The M Resort Spa & Casino
The Quad Resort & Casino
TPC Las Vegas
Treasure Island Spa
Trophy Hills Drive
Tru Las Vegas
Trump Hotel
Vdara Condos
Vdara Hotel & Spa
Veer Towers at City Center
Virgin Las Vegas
Waldorf Astoria
Westin Las Vegas
Wyndham Grand Desert
Wynn Las Vegas Tower



Select California Projects

AC Hotel San Francisco
 Andaz Palm Springs
 Andaz West Hollywood
 Anton Milpitas
 Balboa Bay Club Newport Beach
 Cambria Hotel El Segundo
 Chamberlain Hotel West Hollywood
 Chumash Casino Santa Ynez
 Coronado Island Marriott Coronado
 Courtyard San Francisco
 Courtyard Santa Monica
 Curio Los Angeles
 Delta Anaheim Garden Grove
 Disney Anaheim
 Doubletree Bakersfield
 Doubletree Irvine
 Element San Jose Milpitas
 Embassy Suites Anaheim
 Embassy Suites Santa Clara
 Fairfield Inn Anaheim
 Fairmont San Francisco
 Fairmont San Jose
 Four Points Emeryville
 Four Seasons San Francisco
 Four Seasons Westlake Village
 Furnace Creek Inn Death Valley
 Glenroy Hotel Coachella
 Good Nite Inn Redwood City
 Grand Hyatt San Francisco
 Harbor Court Hotel San Francisco
 Hilton Long Beach
 Hilton Pasadena
 Hilton San Francisco
 Hilton San Jose
 Hilton Santa Cruz
 Holiday Inn LAX
 Holiday Inn Walnut Creek
 Homewood Suites Belmont
 Homewood Suites Mission Valley
 Hotel Corque Solvang
 Hyatt Centric Sacramento
 Hyatt House Irvine
 Hyatt Huntington Beach
 Hyatt Place Pasadena
 Hyatt Regency Newport Beach
 Hyatt Regency San Francisco
 Inn at Spanish Bay Pebble Beach
 Inn at the Mission San Juan Capistrano
 Irvine Spectrum Marriott Irvine
 JW Marriott Desert Springs
 L'Ermitage Beverly Hills
 La Quinta Los Angeles
 La Quinta Orange County
 La Quinta San Luis Obispo
 Le Meridien Arcadia
 Le Meridien Delfina Santa Monica
 Loews Santa Monica
 Marriott Fisherman's Wharf San Francisco
 Marriott Irvine
 Marriott Laguna Cliffs
 Marriott Los Angeles
 Marriott Marquis San Francisco
 Marriott Santa Clara
 Meritage Resort Napa Valley
 Miramonte Resort and Spa Indian Wells
 Montage Laguna Beach
 Newport Villas Newport Beach
 Oceanwide Tower San Francisco
 Perchanga Resort Casino Temecula
 Pullman Sofitel San Francisco
 Renaissance Indian Wells
 Renaissance Newport Beach
 Residence Inn Chula Vista
 Residence Inn San Carlos
 Ritz Carlton Marina Del Rey
 Serrano San Francisco
 Sheraton Agoura Hills
 Sheraton Fisherman's Wharf San Francisco
 Sheraton La Jolla
 The Cliff Royal Sonesta San Francisco
 The Lodge at Torrey Pines La Jolla
 Thunder Valley Casino Lincoln
 TownePlace Suites San Diego
 W Hotel Los Angeles
 W Hotel San Francisco
 Waldorf Astoria Beverly Hills
 Westin Los Angeles
 Westin San Diego
 Westin St. Francis San Francisco
 Wilshire Grand Hotel Los Angeles
 Wine Country Inn Napa
 WorldMark Indio
 Wyndham Visalia
 Yotel San Francisco





Custom Framed Trinity Lighted Mirror
Le Meridien Arcadia, Los Angeles
Linda Snyder Associates, Designer



Integrity Lighted Mirror
Mandarin Oriental, San Francisco
BAMO, Designer



Silhouette Lighted Mirror TV
Ritz Carlton, Los Angeles
HBA, Designer



Custom Stanford Mirror TV
Shangri-La, Vancouver
James Cheng Architects, Designer





Custom Reflection Lighted Mirror TV
Fairmont Pacific Rim, Vancouver
Chil Design Group, Designer



Custom Framed Novo Lighted Mirror
Four Seasons, Montreal
Gilles et Boissier, Designer

Select Canada Projects



1 Hotel Toronto ON
Andaz Ottawa ON
Arts Hotel Calgary AB
Bear Mountain Resort Victoria BC
Best Western Downtown Vancouver BC
Calgary Petroleum Club Calgary AB
Canadian Pacific Railway AB
Canopy Yorkville Toronto ON
Chateau Frontenac Quebec QC
Coast Inn of the North Prince George BC
Courtyard Calgary AB
Courtyard Cold Lake AB
Courtyard Prince George BC
Courtyard Toronto ON
Dakota Dunes Resort Whitecap SK
Dartmouth Hotel Halifax NS
Delta Calgary South AB
Delta Toronto ON
Delta Mississauga ON
Delta Regina SK
Delta Winnipeg MB
Doubletree Toronto ON
Embassy Suites Niagara ON
Epic Tower Vancouver BC
EXchange Hotel Vancouver BC
Executive Hotels Burnaby BC
Fairmont Chateau Laurier Ottawa ON
Fairmont Chateau Whistler BC
Fairmont Empress Victoria BC
Fairmont Jasper Park Lodge Jasper AB
Fairmont Le Chateau Frontenac Quebec QC
Fairmont Le Manoir Richelieu La Malbaie QC
Fairmont Pacific Rim Vancouver BC
Fairmont Queen Elizabeth Montreal QC
Fairmont Royal York Toronto ON
Fallsview Casino Niagara Falls ON
Forever Yours Langley City BC
Four Points Niagara Falls ON
Four Seasons Montreal QC
Four Seasons Toronto ON
Georgian Court Vancouver BC
Grosvenor Ambleside West Vancouver BC
Guillevin International Calgary AB
Hampton Inn Calgary AB
Hilton Niagara Falls ON
Hilton Toronto ON
Holiday Inn Airdrie AB
Holiday Inn Colwood BC
Holiday Inn Gatineau QC
Holiday Inn Kamloops BC
Holiday Inn Niagara ON
Holiday Inn St. Johns NB
Holiday Inn Toronto ON
Hotel Saint-Amable Quebec QC
Hotel X Toronto ON
Howard Johnson Windsor ON
Hyatt Place Edmonton AB
InterContinental Toronto ON
JW Marriott Edmonton AB
King Edward Hotel Toronto ON
Le Marchand Mansion Edmonton AB
Le Soleil Vancouver BC
Lisgar Condos Ottawa ON
Living Water Resort Collingwood ON
Marriott Calgary Airport AB
Marriott Gateway Fallsview ON
Marriott Markham ON
Marriott Renaissance Montreal QC
Masterpiece Senior Living Medicine Hat AB
Moose Hotel Banff AB
Novotel Montreal QC
One King West Hotel Toronto ON
Park Hyatt Toronto ON
Radisson Hotel Vancouver BC
Radisson Plaza Saskatchewan SK
Ritz Carlton Montreal QC
Shangri-La Vancouver BC
Sheraton Cavalier Saskatoon SK
Sheraton Center Toronto ON
Sheraton Eau Claire Calgary AB
Sheraton Parkway Toronto ON
Sheraton Saint-Hyacinthe QC
Sheraton Toronto Airport ON
Sheraton Vancouver Wall Center BC
Staybridge Suites Niagara ON
Strathcona Village Vancouver BC
The Artemisia BC
Trump Toronto ON
Trump Vancouver BC
Westin Edmonton AB
Westin Harbor Castle Toronto ON
Westin Nova Scotian Halifax NS
Westin Tremblant QC
Westin Vancouver BC

Select Latin America Projects

Albany House Bahamas	Ikin Margarita Hotel Venezuela
Amanyara Resort Turks and Caicos	InterContinental Mexico City Mexico
Avid Fresnillo Mexico	Kirschner Residence Puerto Rico
Avid Tijuana Mexico	Las Brisas Bolivia
Baha Mar Bahamas	Le Blanc Spa Resort Mexico
Blazquez Residence Puerto Rico	Mall Metrocentro El Salvador
Breathless Hotel Cancun Mexico	Marriott Costa Rica
Bristol Hotel Panama	Marriott Georgetown Guyana
Bucuti & Tara Beach Resort Aruba	Marriott Ocean Club Aruba
Caribe Hilton San Juan Puerto Rico	Marriott San Juan Costa Rica
Casa Higuera-Maravilla Mexico	Marriott Santa Cruz Bolivia
Celebrity Equinox Bahamas	Marriott Westin Lagunamar Mexico
Club Princess Dominican Republic	Moon Palace Jamaica Grande Jamaica
Courtyard Juarez Mexico	One and Only Ocean Club Bahamas
Courtyard San Juan Puerto Rico	Panama Marriott Panama
Custom Villa Cabo Mexico	Pegasus Hotel Guyana
Dakota Quay Grand Cayman	Peril Bagno Mexico
Dolce Vita Cayman Islands	Radisson Grenada
Eagle Aruba	Renaissance Aruba Resort Aruba
El Blok Hotel Puerto Rico	Residences by Grace Bay West Indies
El Conquistador Puerto Rico	Ritz Carlton Grand Cayman Cayman Islands
Fairmont Heritage Mayakob Mexico	Ritz Carlton Mexico City Mexico
Four Points Galerias Mexico	Ritz Carlton St. Thomas U.S.V.I.
Four Points Punta Cana	Rodriguez Residence Mexico
Four Seasons Punta Mita Mexico	Rosewood Baha Mar Bahamas
Four Seasons Sao Paulo Brazil	Royal Isabella Puerto Rico
Frenchmans Reef Marriott U.S.V.I.	Sangster International Airport Jamaica
Goldwynn Bahamas	Scrub Island Resort British Virgin Islands
H2O Residence British West Indies	Secrets Punta Cana Dominican Republic
Hampton Inn Juarez	Sheraton Old San Juan Puerto Rico
Hampton Inn Monterrey Gal Mexico	Sheraton Santo Domingo Dominican Republic
Hampton Los Cabos Mexico	St. Regis Mexico City Mexico
Hilton La Romana Dominican Republic	St. Regis Puerto Rico
Holiday Inn Chihuahua Mexico	Tara Beach Suites & Spa Aruba
Holiday Inn Express Managua Nicaragua	The Audiophile Group Cayman Islands
Holiday Inn Hermosillo Mexico	Trump International Hotel Panama
Holiday Inn Honduras	Villa Chill Turks and Caicos
Holiday Inn San Jose Costa Rica	Villas Mayakoba Mexico
Hotel El Convento Puerto Rico	W Santiago Chile
Hotel en Tuxpan Veracruz Mexico	Waldorf Astoria El Conquistador Puerto Rico
Hotel Las Brisas Bolivia	Waldorf Astoria Panama
Hotel Mesa Luna Mexico	West San Isidro Peru
Hotel Santa Clara Colombia	Westin Cancun Mexico
Hyatt Punta Cana Dominican Republic	Westin Grand Cayman Cayman Islands
Hyatt Place San Juan Puerto Rico	Westin St. John Virgin Grand U.S.V.I.
Hyatt Regency Aruba	Wyndham Grand Rio Mar Puerto Rico
Hyatt Regency Trinidad and Tobago	Wyndham Margaritaville St. Thomas U.S.V.I.





Eternity Lighted Mirror
Sandals, Barbados
Hospitality Purveyors, Inc., Designer

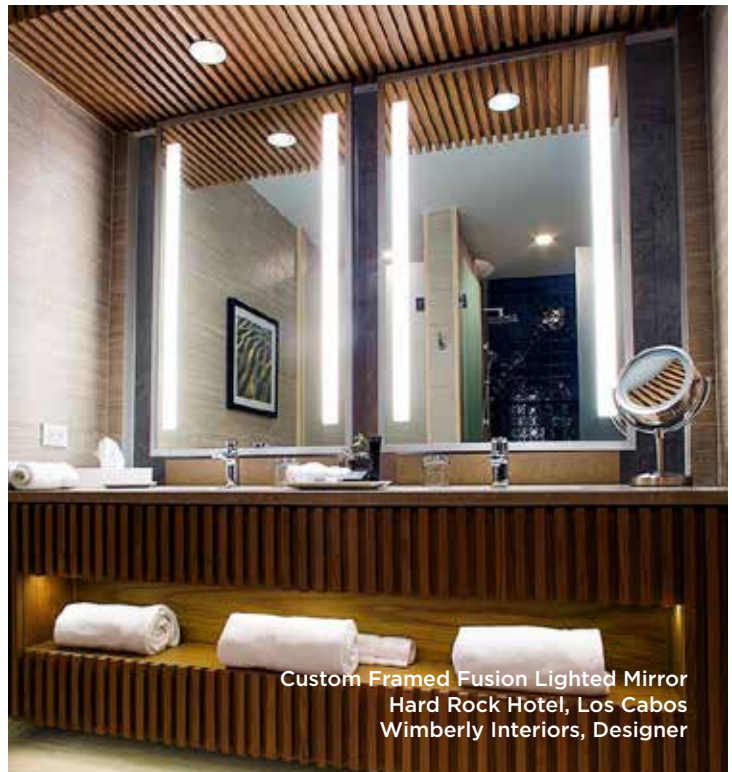

Custom Framed Fusion Lighted Mirror
Hard Rock Hotel, Los Cabos
Wimberly Interiors, Designer



Custom Integrity Lighted Mirror
Intercontinental Presidente, Mexico
Ramos Interiors, Designer



Silhouette Lighted Mirror
Darling at the Star Gold Coast, Australia
Bates Smart, Designer



Custom Stanford Mirror TV
Waldorf Astoria, Jerusalem
Metex Design Group, Designer



Custom Lighted Mirror TV
Ritz Carlton, Egypt
Frank Nicholson, Inc., Designer

Select Europe, Africa and Oceania Projects



- 45 Park Lane London England
- 85 Buckingham Gate England
- AE Segraeti Monaco
- Al Houara Hotel Morocco
- Astral Hotel Australia
- Balmoral Hotel Edinburgh Scotland
- Baltic Yachts Finland
- Bolsover Street England
- Bond Lounge Bar Australia
- Campbelltown Catholic Club Australia
- Celebrity Constellation Spain
- Celebrity Eclipse Germany
- Celebrity Reflection Germany
- Celebrity Silhouette Germany
- Corinthia Hotel England
- Crown Plaza St. James England
- Crown Sydney Australia
- Crystal Cruises Germany
- Elektro Switzerland
- Ethiopia Airport Ethiopia
- Firmdale Hotel United Kingdom
- Four Seasons Bora Bora French Polynesia
- Four Seasons Casablanca Morocco
- Four Seasons Geneva Switzerland
- Four Seasons George V France
- Four Seasons Hampshire England
- Four Seasons London Trinity England
- Four Seasons Moscow Russia
- Four Seasons Paris France
- Four Seasons Park Lane England
- Four Seasons Sharm El Sheikh Egypt
- Four Seasons St. Petersburg Russia
- Four Seasons Sydney Australia
- Grand-Hotel du Cap-Ferrat France
- Halcyon Villas Cyprus
- Hilton Doubletree Poland
- Hilton Euston England
- Hilton Hyde Park England
- Hilton Park Lane England
- Hilton Southbank England
- Holland America Ireland
- Holland America Italy
- Hotel d'Aubusson France
- Hotel Hassler Rome Italy
- Hotel Le Parc France
- Hotel Maria Cristina Spain
- Hyatt Regency London England
- Jumeirah Carlton Tower England
- Justice and Police Museum Australia
- K + K Hotel Fenix Czech Republic
- K + K Hotel Opera Budapest Hungary
- Lady Telecom Spain
- Laucala Island Resort Fiji
- Le Royal Monceau Raffles France
- Leo Palace Resort Guam
- Mandarin Oriental Geneva Switzerland
- Mandarin Oriental London England
- Mandarin Oriental Munich Germany
- Marriott Budapest Hungary
- Mercure Windsor England
- MJM Millennium Ship Northern Ireland
- MJM Royal Suites Northern Ireland
- Mondrian London England
- Movenpick Paris France
- NEC World Resorts England
- Novotel Rockford New South Wales
- Novotel Sydney Darling Australia
- Park Hyatt Mallorca Spain
- Park Inn Amsterdam Netherlands
- Piccolino Australia
- Prince De Galles France
- Pullman London England
- Pullman London St. Pancras England
- Radisson Blu Nydalen Oslo Norway
- Radisson Blu Reykjavik Iceland
- Raffles Istanbul
- Regent Seven Seas Italy
- Renaissance Heathrow England
- Renaissance Paris La Defense France
- Ritz-Carlton Bulgari London England
- Ritz-Carlton Cairo Egypt
- Ritz-Carlton Istanbul Turkey
- Rosari Switzerland
- Royal Caribbean Northern Ireland
- Sofitel Mogador France
- St. Ermin's Hotel England
- The Berkley Hotel England
- Westin Warsaw Poland

Select Asia and Middle East Projects

Address Dubai UAE	Mandarin Oriental Jakarta Indonesia
Al Faisaliah Hotel Saudi Arabia	Mandarin Oriental Taipei Taiwan
Amaya Resort Kuda Rah Maldives	Marriott Manilla Philippines
Amwaj Villa Bahrain	MGM Ho Tram Vietnam
Arnhold Hong Kong	MGM Macau
Azrak Villa Qatar	Mira Hotel Saudi Arabia
Barbers Mirrors UAE	Mondrian Doha Qatar
Bayat Hotel Saudi Arabia	Movenpick Colombo Sri Lanka
Beach House Jeddah Saudi Arabia	Musherib Hotel Doha Qatar
Blue Water Seven Bays UAE	Nobu Hotel Saudi Arabia
Bridgeway Hotel Abu Dhabi UAE	Novotel Abu Dhabi UAE
Conrad Istanbul Hotel Turkey	Oberoi New Delhi India
Conrad Manila Hotel Philippines	One and Only Reethi Rah Maldives
Darwish Bin Ahmed UAE	Park Hyatt Hyderabad India
Discovery Primea Hotel Philippines	Park Inn Daunas Lithuania
Dream Hotel Doha Qatar	Radisson Blu Latvia
Fairmont Baku Azerbaijan	Raffles Istanbul Turkey
Fairmont Riyadh Saudi Arabia	Raffles Singapore
Fortress Hotel Galle Sri Lanka	Residences Dubai Opera UAE
Four Seasons Abu Dhabi UAE	Ritz-Carlton Astana Kazakhstan
Four Seasons Amman	Ritz-Carlton Bahrain
Four Seasons Bahrain Bay Bahrain	Ritz-Carlton Hong Kong
Four Seasons Beijing China	Rosewood Abu Dhabi UAE
Four Seasons Bengaluru India	Salwa Resort Qatar
Four Seasons Jumeirah Beach Dubai UAE	Sands Macao Macau
Four Seasons Riyadh Saudi Arabia	Saraya One Tower Abu Dhabi UAE
Four Seasons Tokyo Japan	Shangri-La Hotel Qufu China
Grand Hyatt Kuwait	Sheraton Makkah Saudi Arabia
Grand Hyatt Manila Philippines	Sheraton Yokohama Bay Japan
Hilton Batumi Georgia	Sir Bani Yas UAE
Hilton Doubletree Saudi Arabia	Sofitel Dubai UAE
Hyatt Abu Dhabi UAE	Solaire Hotel Manila Philippines
Hyatt Centric Dubai	St. Regis Kuala Lumpur Malaysia
Hyatt City of Dreams Philippines	St. Regis Saadiyat UAE
InterContinental Regency Bahrain	Taj Mahal Mumbai India
Jumeirah Beach Hotel UAE	Tufenkian Heritage Armenia
JW Marriott Doha Qatar	Venetian Orient Limited Macau
Kempinski Hotel Mall of the Emirates UAE	W Cotai Macau
King Abdallah Financial Saudi Arabia	W Maldives Maldives
Le Meridien Dubai Hotel UAE	Waldorf Astoria Jerusalem Israel
Leisure Manila Philippines	Waldorf Astoria Ras Al Khaimah UAE
Lotte Hotel Hanoi Vietnam	Westin Makkah Saudi Arabia
Lumatron Qatar	Westin Singapore
Lux South Air Atoll Maldives	Wynn Palace Cotai Macau





Custom Fusion Lighted Mirror TV
Four Seasons, Guangzhou
HBA, Designer



Custom Stanford Mirror TV
Four Seasons, Baku
Richmond International, Designer



Custom Quad Fusion Lighted Mirror
Four Seasons, Tokyo
ILYA Corporation, Designer



Integrity Lighted Mirror
O Spa, California
Designstudio Ltd, Designer

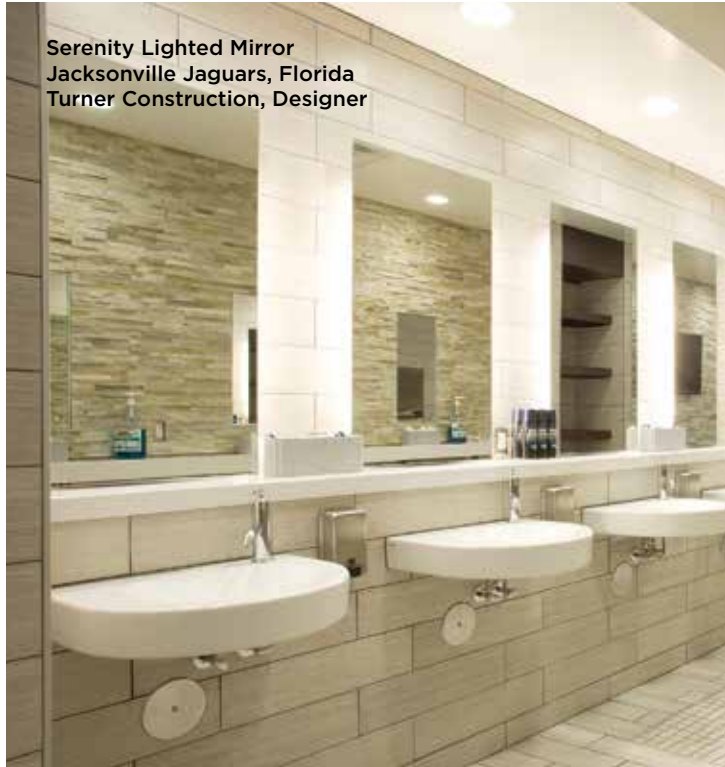

Serenity Lighted Mirror
Jacksonville Jaguars, Florida
Turner Construction, Designer



Integrity Lighted Mirror
Arsova Salon, Illinois
Arsova Salon, Designer

Select Commercial Projects

Adobe CA
Alaska Airlines WA
Amazon Headquarters WA
AMC Networks NY
American Airlines Admiral Club TX
Apple CA
AT&T MN
Bank of America NY
Belmont Country Club MA
Best Buy BC
Boston Consulting Group MA
Boston Celtics MA
Bristol Myers Squibb NJ
British Airways CA
Canadian Pacific Railway AB
Capital One MD
CBS News DC
CBRE CO
Chateau Elan Winery GA
Chick Fil A GA
Cisco CA
Citybank NY
Costco Corporate Office WA
Cushman Wakefield NY
Dallas Fort Worth Airport TX
Daytona Speedway FL
DC Convention Center MD
Deloitte University TX
Denver Gateway Center CO
Detroit Red Wings MI
Disney FL
eBay CA
Facebook WA
Federal Reserve Bank CA
Fed Ex IN
Ferrari CA
Google NY
Harvard University MA
Honda IL
Hudson Yard NY
Intel CA
Jacksonville Jaguars FL
Jaguar Land Rover AZ
Johnson and Johnson CA
JP Morgan Chase NY
Kansas City Chiefs MO
La Guardia Airport NY
Las Vegas Raiders Stadium NV
LG Headquarters NJ
Lockheed Martin CA
Mastercard NY
Mercedes TX
MetLife CA
Microsoft CA
Milwaukee Bucks WI
Morgan Stanley NY
NBA NY
NBC Rockefeller Center NY
Netflix CA
New York Life NY
New York Yankees NY
Nordstrom CA
Perry Ellis NY
Pfizer Headquarters NJ
Planet Hollywood NV
Price Waterhouse Cooper NC
Proctor and Gamble IA
Publix CA
Revlon NJ
Rolls Royce CA
SeaTac International Airport WA
Sirius XM CA
Southwest Airlines TX
Spotify NY
State Farm TX
T. Rowe Price NY
Time Warner Center NY
T-Mobile SC
Top Golf IN
Trammel Crow Center TX
Twitter WA
UBS Financial NY
Under Armour MD
United Airlines CA
Universal Studios FL
US Airways AZ
US Army Corp of Engineers MD
US Bank CA
Verizon DC
Visa NJ
Washington Convention Center WA
Wells Fargo CO
Wrigley Field IL
YouTube CA



Select Multi-Family Projects

Affinia Fifty NY
 Anton Milpitas CA
 Arbor Points MA
 Aston Martin Residences FL
 Atlantic Palace NJ
 Ava Hollywood CA
 Avalon West Hollywood CA
 Axel Interbay Apartments WA
 Balboa Newport Beach CA
 Ballpark Village CA
 Beverly West CA
 Blackburn Inn VA
 Blossom Plaza CA
 Brattons Edge TX
 Broadstone North Getty CA
 Bunker Hill Condos CA
 Cache CA
 Capital Crest Apartments FL
 Capri Apartments FL
 Century Apartments DC
 Chevy Chase Lake MD
 Chorus CA
 Deco Apartments WI
 Dunvale Apartments TX
 Edition Miami Residences FL
 Elysium Logan DC
 Esperanza CA
 Excelsior Apartments GA
 Exhale Inman Quarters GA
 Goddard House MA
 Gramercy Square NY
 Grand Canyon Apartments NV
 Highlands Apartments CA
 Hudson Yards NY
 Icon Apartments MT
 Indigo Apartments CA
 Ironworks Apartments CA
 Jefferson Triangle CA
 Kingsmill Cottages VA
 Lakehouse on 17th CO
 Landmark CA
 Lane Field South Suites CA
 Larstrand NY
 Laurel Rittenhouse Square PA
 Le Meridian Oakbrook IL
 LSE Residential Tower WA
 Marlow Apartments IL
 McKenzie WA
 Metropolis CA
 Mira Tower CA
 Mountain Shadows Condos AZ
 Nexus WA
 Noho Lofts CA
 North Hill Avery MA
 North Shore Apartments NY
 North+Vine Apartments IL
 One88 Bellevue WA
 One City TN
 Palazzo Westwood Village CA
 Park Fountain Apartments TX
 Park Place Apartments CA
 Parks Edge Condos OH
 Pioneer Condos TX
 Pleasanton Apartments CA
 Project Sorrento FL
 Prometheus CA
 Queens Park Plaza NJ
 Radian Boston MA
 Rafter Apartments MN
 Rainier Square WA
 Recon Apartments IL
 Renaissance Schaumburg IL
 Residences at Marina Bay MA
 Ritz-Carlton Apartments IL
 Riverwalk MA
 Seaport Multi Family MA
 Skye at Arbor Lakes MN
 Soma Housing CA
 Spruce Peak MA
 St. Regis Residences NY
 The Commons at Ballard WA
 The Dean CA
 The Highlands OK
 The Locks Tower VA
 The Muse AZ
 The Point Condos MA
 The Quarter OH
 Two Lincoln Tower WA
 Vermella Apartments NJ
 Westchester Apartments CA
 Westlake Steps WA
 Wilshire Crescent CA
 Wonder Lofts NJ
 Woodmont Stonehall Condos VA





Custom Quad Fusion Lighted Mirror TV
One Bal Harbour, Florida
CMMI, Designer



Novo Lighted Mirror
Beverly West Residences, California
Plum Design West, Designer



Custom Integrity Lighted Mirror
One88 Bellevue, Washington
Graphite Design, Designer



Integrity Lighted Mirror
Martha Jefferson Hospital, Virginia
Kahler Slater, Designer



Trinity Lighted Mirror
Integrative Health & Wellbeing, New York
HOK, Designer

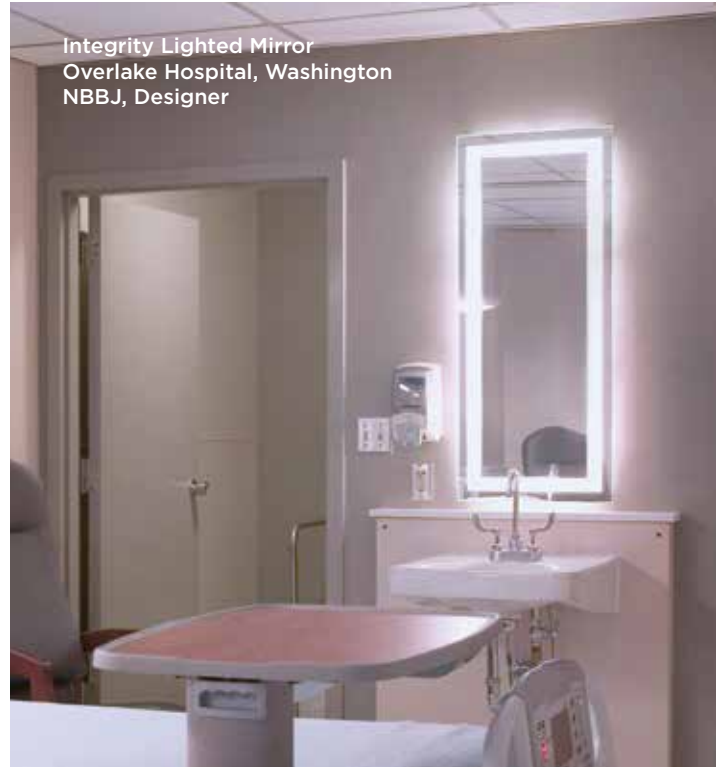

Integrity Lighted Mirror
Overlake Hospital, Washington
NBBJ, Designer



Select Healthcare and Senior Living Projects

Abbot Northwestern MN
Advent Health FL
Advocate South Suburban Hospital IL
Alexandria Memory Care VA
Allegro at Casselberry FL
Arkansas Children's Hospital AR
Assisted Living Collierville TN
Atrium Health FL
Aurora Lakeland Women's Hospital WI
Blue Cross Blue Shield MA
Bridgeport Hospital NICU CT
Brigham Women's Hospital MA
Bristol-Meyers Squibb PA
Brookstone Gardens NE
Bryan Medical Center NE
Calusa Harbour Senior Living FL
Cancer Center of Santa Barbara CA
Carbondale Memorial Hospital IL
Carillion Memorial Hospital VA
Cedar Sinai CA
Centegra Huntley Hospital IL
Central DuPage Hospital IL
Children's Healthcare GA
Children's Hospital of Colorado CO
Covenant Woods VA
Cox Medical Center MO
Delnor Community Hospital IL
Dignity Health AZ
Florida Hospital Wesley Chapel FL
Forest Park Medical TX
Gothenburg Memorial Hospital NE
Hardin Memorial Hospital KY
Hegg Memorial Health Center IA
Henry Ford Hospital MI
Houston Methodist Hospital TX
Huguley Hospital TX
Immuno Mycologics OK
Inova Schar Cancer Institute VA
Iowa Methodist Medical Center IA
John Hopkins Medicine MD
Kaiser CA
Kaleida Children's Hospital NY
La Posada Assisted Living FL
Lakeland Regional Hospital FL
Lancaster General Hospital PA
Liberty Health Living KS
Masterpiece Senior Living AB
Mayo Clinic FL
Memorial Sloan Kettering NY
Mercy Health MI
Metrohealth Medical OH
Mid-Hudson Regional Hospital NY
Midland Memorial Hospital TX
Mt. Carmel East Hospital OH
Mount Sinai Morningside NY
Nationwide Children's Hospital OH
New Orleans East Hospital LA
North Central Baptist Hospital TX
Northeast Georgia Medical Center GA
New York Presbyterian Hospital NY
New York University Langone Health NY
Ocean Medical Center NJ
Olathe Medical Center KS
Orlando VA Hospital FL
Parkway Surgery Hospital TX
Puller Veterans Care Center VA
Rehab Hospital of the Pacific HI
Rehab Institute of Chicago IL
Renaissance Westchester NY
Riverside Hospital OH
Sagewood Senior Living AZ
Seattle Children's Hospital WA
Sedgebrook Retirement IL
St. Francis Hospital Litchfield IL
St. Jude Children's Hospital TN
Stamford Hospital CT
Stanford Health CA
Tallahassee Memorial Hospital FL
Texas Presbyterian Hospital TX
University of Arizona Biosciences AZ
University of Houston Health TX
Valley Hospital NJ
Veterans Administration Topeka KS
Vi Living Aventura FL
View Royal Surgical BC
Vistas at Providence Park PA
Wake Medical Hospital NC
Washington Hospital DC



A large, vibrant rainbow arches across a dramatic, cloudy sky at sunset. The sun is low on the horizon, casting a warm, golden glow over a park scene. In the foreground, a paved plaza with a grid pattern leads to a large, ornate fountain with a central sculpture. The fountain's water is illuminated by the sunset light. In the background, there are trees and a fence. The overall atmosphere is serene and beautiful.

OUR CAPABILITIES



Eiffel Tower
Paris, France

Customization Expertise

Electric Mirror has the in-house capabilities, knowledge, and expertise to transform your brilliant ideas into brilliant products.



Custom Framed Fusion Lighted Mirror
Inn at the Mission, California
Kay Lang & Associates, Designer

A COMPREHENSIVE APPROACH

No matter how novel or unique your idea might be, Electric Mirror has everything necessary to take your concept from ideation through to production. We implement a multi-disciplinary process from start to finish, involving a significant number of our 200 team members to create and deliver a product that not only meets, but exceeds, your expectations.

CONCEPT DEVELOPMENT

We start by really listening, to ensure we understand your vision as well as you do. We evaluate the product requirements and key features you're looking for. Working with our in-house Research and Development team, we assess various approaches, ensuring each is feasible from both an engineering and manufacturing perspective. Then we propose a recommended solution for your consideration.



PRODUCT ENGINEERING

Once you've approved a design concept, we move forward with prototype engineering. We create electrical and mechanical engineering plans, ensuring the product will meet or exceed all code and certification requirements. We conduct an engineering assessment of key components, followed by a sourcing review to ensure all components are readily available. Then we create full documentation packets for building a prototype.

PROTOTYPE FABRICATION

With design and engineering complete, we move into prototype fabrication. Raw materials are gathered and assembled to produce the metal, electrical and mirror glass components of your product. Then, with Bill of Material (BOM) and Method of Manufacturing (MOM) documentation in hand, we create a First Article product.



QUALITY ASSURANCE

The First Article then goes through a rigorous inspection and review process with Engineering, Manufacturing, and Quality Assurance teams. Light testing is conducted, and a photometric assessment is completed. The prototype is reviewed to ensure it meets the original design, functionality, and usability requirements. If changes are required, they're documented, addressed, and a new prototype is produced for review.

MANUFACTURING PRODUCTION

With an approved prototype in hand, we move to the final stage—manufacturing production. We make any necessary updates to BOMs, MOMs and processes and their corresponding documentation to ensure consistency in manufacturing. We implement quality control and assurance processes specific to your product. And mindful still of your original vision, we bring your product to life.



Custom Concepts

If you can dream it, we can build it – from interesting shapes that captivate your attention to unique sizes that fit your space, no idea is beyond our capabilities.



Custom Integrity Lighted Mirror
Tameer Tower Model Room, Dubai
LW Design Group, Designer

CUSTOM SHAPES

We've collaborated with clients worldwide to create extraordinarily-shaped mirrors that excite the senses. Working together, we imagineer stunning products that achieve your vision and integrate seamlessly into your overall space.*



Custom Framed Integrity Lighted Mirror
Higgins Hotel, New Orleans
Kay Lang & Associates, Designer



Custom Quad Fusion Lighted Mirror TV
 Bal Harbour Hotel, Miami
 CMMI, Designer



Custom Novo Lighted Mirror
 Four Seasons, India
 Yabu Pushelberg, Designer



Custom Silhouette Lighted Mirror
 45 Park Lane Hotel, London
 Thierry W Despont, Designer

CUSTOM SIZES

The ideal mirror becomes the perfect mirror when it fits your exacting space requirements. For those times when a standard size isn't quite right, we'll create the custom size you need to create a flawless finish to your design.*

*Custom designs and custom sizes are available for large quantity orders.

Custom Designs

Make a beautiful statement with the incredible detail and elegant luxury of a custom frost pattern lighted mirror.



Custom Frost Pattern Lighted Mirror
Sheraton Hotel, Indianapolis
Remington Hotels, Designer

FIND YOUR INSPIRATION

Every great design starts with inspiration. At Electric Mirror, our designers find inspiration everywhere—from Santa Fe mosaic tiles to folded rose petals. With Cameo™ Designs*, you can choose from a selection of our patterns or get inspired to design your own.



Custom Frost Pattern Lighted Mirror
Higgins Hotel, New Orleans
Kay Lang & Associates, Designer

EXPRESS YOUR STYLE

From strikingly simple, to sophisticatedly sleek, to interestingly intricate, Cameo Designs let you express your personal style and taste. Cameo turns your lighted mirror into an integral part of your décor, complementing and accentuating your overall design theme.



Custom Frost Pattern Lighted Mirror
Washington Plaza Hotel, Washington D.C.
Forrest Perkins, Designer

CREATE A CENTERPIECE

Our custom frost pattern mirrors are more than a functional lighting element—they're a spectacular focal point of artistic expression. With Cameo Designs, your lighted mirror becomes the center of attention, creating a memorable experience that's sure to be shared.

*Cameo Designs are available for large quantity orders.

Custom Frames

Add the distinctive panache of a beautiful and stylish frame to your mirror for a truly unique visual masterpiece without equal.



THE BEST SELECTION

If you're looking for custom frames, no one offers more choices than Electric Mirror. Choose from metal, wood, polystyrene, and other options, in widths ranging from less than 1" to more than 5". Select from hundreds of profiles, colors, and finishes – or create your own. With virtually limitless options, we're certain we can create exactly what you're looking for*.

METAL FRAMES

The thin profile of metal frames provides a refined look and modern finish to our lighted mirrors, perfectly complementing your contemporary décor. Ideal for unique shapes – including radius corners, rounds and ovals – our metal frames are available in a vast array of finishes and colors. If clean lines and a sleek look are what you're after, metal frames are the way to go.



WOOD FRAMES

Nothing matches the luxury of classic wood frames for creating a warm and timeless look for your lighted mirrors. From standard substrates such as ash, oak, and pine, to exotic hardwoods like ayous, obeche and jelotong, wood frames give lighted mirrors a beautifully-handcrafted appearance. Wood frames are best suited for square and rectangular mirrors; and whether your style is basic or Bohemian, rustic, or regal, we can work with you to create the perfect frame for your next project.

POLYSTYRENE FRAMES

These frames are not only beautiful, they're beautifully made. The process starts by recycling polystyrene products and repurposing them into extruded moldings. The extrusions can then be finished in virtually any color, any finish, and any texture conceivable—currently 50,000 variations and counting. Polystyrene can also be used for ornate, custom molded frames with intricate designs. With this innovative and exclusive approach to framing, you're beautifying your project and your planet, all at once.



*Custom frames are available for large quantity orders.



OUR VALUE



Big Ben
London, England

Multi-Disciplinary Team Approach

When you choose Electric Mirror, you're getting the world's largest multi-disciplinary team of mirror-technology experts working on your behalf.



ACCOUNT MANAGEMENT

It starts with a global sales leadership team that brings extensive experience from multiple industry avenues, including interior design and hospitality management. It includes a robust group of sales representatives focused on knowing you, your market, and your projects. It continues with dedicated account managers that provide the product information you need. And it's supported with project coordinators who see your job through from start to finish, ensuring everything runs smoothly and according to plan.

RESEARCH AND DEVELOPMENT

Our R & D team members are masters of ingenuity. What new products do our customers need? What new technologies would provide value-added functionality? How can we improve the user experience? They set about to answer those questions, and along the way, develop groundbreaking new mirror technology products. To date, that spirit of invention has garnered over 20 industry awards, as well as over 60 design and utility patents.

ENGINEERING

We offer the largest engineering team in the industry, with over 20 design, electrical, mechanical and software engineers. Every day, they turn art into science and ideas into reality. Armed with extensive experience and the most sophisticated tools available, they translate product concepts into product blueprints, ready for manufacturing.



MANUFACTURING

It takes a lot of people to fill a 125,000 square foot manufacturing facility. And Electric Mirror's got them. Experts who cut, edge, bevel, laser and polish our mirrors. Machinists who punch, press, bend and weld our chassis. Technicians who measure, cut, and assemble our wire harnesses. Artisans who build our wood and metal frames by hand. And specialists who bring it all together by assembling our beautiful mirror technology products.

QUALITY ASSURANCE

Any idea is only as good as its execution, so we employ quality assurance experts, policies, and procedures every step of the way. Internationally-sourced components undergo vigorous qualification testing and ongoing monitoring. In-house, we establish stringent quality criteria and conduct ongoing review and testing of our products, ensuring they're perfect before they leave our plant.



LOGISTICS

Once they're ready to go, our logistics team gives every product the white-glove treatment. Packaging boxes are custom-designed for each unique product, and produced using computer-aided cutting and configuration equipment. Our in-house woodshop team builds custom crates for each job, sized to protect your precious cargo. And our shipping experts - with extensive global logistics experience - coordinate the details so your products arrive on time and in perfect condition.

CUSTOMER SERVICE

We do everything possible to ensure our company and our products provide an outstanding experience. So we have a team of experts on hand to address any questions or issues that may arise. Housed at our U.S. corporate headquarters, they have instant access to engineering, manufacturing and quality experts throughout our facility. And should you need on-site assistance, our anytime, anywhere field service team is only a phone call away.

Extensive Manufacturing Capabilities

Only Electric Mirror offers you the manufacturing capabilities that come from being the global leader in mirror technology products.



MULTIPLE MANUFACTURING FACILITIES

At times, different clients or projects may call for different manufacturing solutions. For some, complete customization capabilities are paramount, while for others, off-the-shelf products will suffice. Sometimes quick access to stock items and easy replacements are the driver, while other times it's cost that matters most. That's why we offer both a U.S.-based manufacturing plant at our global headquarters, as well as additional contract manufacturing in Asia. Having multiple options allows us to use the best solution for your product, timeline, and project location.



COMPLETE VERTICAL INTEGRATION

Because we have everything literally under one roof – engineering, electronics, sheet-metal production, mirror fabrication, wood crafting, mirror assembly, packaging, and shipping – we have complete manufacturing control over your products from start to finish. We ensure everything works together, and eliminate the challenge of dealing with multiple suppliers.



QUALITY ASSURANCE

To ensure our products exceed your expectations, we employ rigorous quality assurance measures at every stage. In our U.S. facility, a multidisciplinary Quality Team assesses critical quality checkpoints in engineering, model room orders, production runs, packaging and even shipping. At our international facilities, on-site quality engineers conduct ongoing facility qualifications and production evaluations.

STOCK AND STAT ITEMS

When time is tight, we've got you covered. Because most of our products are made in our vertically-integrated U.S. facility, there's no lengthy delay between vendors, resulting in lead times unmatched anywhere in the industry. Need it yesterday? We also offer many stock items ready for immediate shipping.

ADDITIONS AND REPLACEMENTS

Regardless of which facility produced your original products, if you need a few extras, or you need a quick replacement part, we can make it for you fast at our U.S. plant.

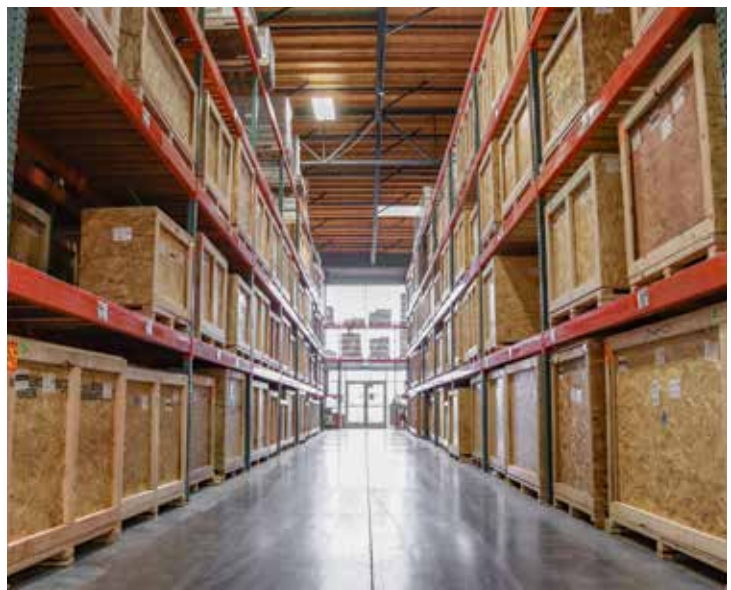

Superior Product Performance

Independent TUV testing proves OmegaMirror™ outlasts other mirrors at least 6 to 1.

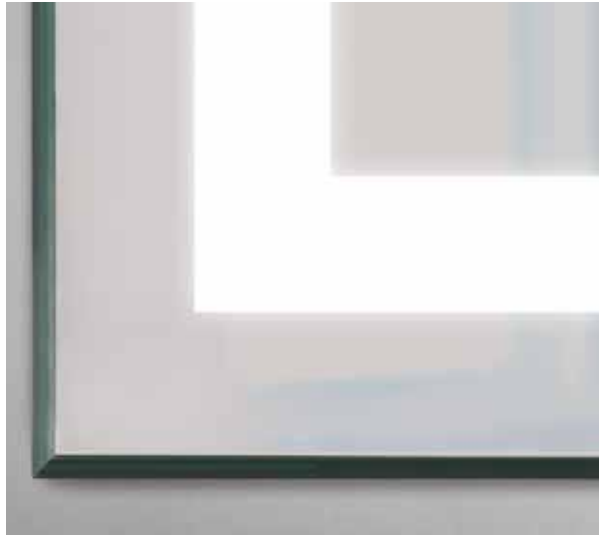

OmegaMirror

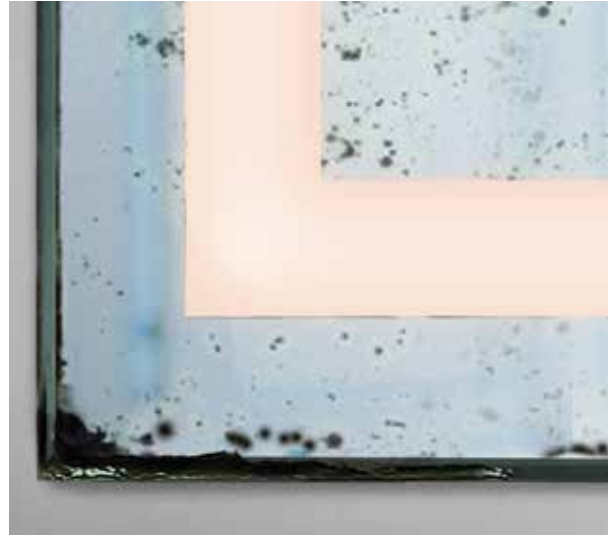

Other Mirrors

INSIST ON THE PROVEN, MOST DURABLE MIRROR FOR THE BATHROOM.

Mirrors subjected to a humid bathroom environment are prone to unsightly corrosion, so it's imperative any purchasing decision take into consideration the mirror's durability. The CASS¹ Testing Method, conducted by independent labs like UL and TUV, is the universally-preferred test for verifying the longevity of mirror products under harsh conditions.

With CASS Testing, most mirrors show signs of de-silvering, clouding and corrosion after only 75 hours. In comparison, OmegaMirror is rated "essentially faultless" after 480 hours of CASS testing, providing more than six times the corrosion-free durability and longevity of other mirrors.

The OmegaMirror Advantage

- Six times longer life
- Independently CASS tested
- 10-year warranty
- Lead and copper-free

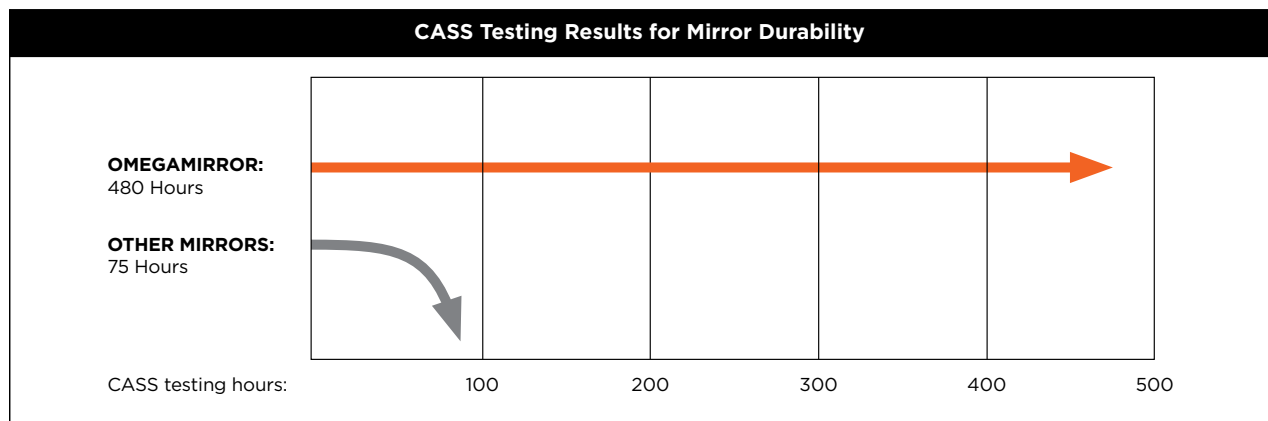

INSIST ON THE MIRROR THAT SAFEGUARDS YOUR REPUTATION.

In environments like hotels, apartments, and hospitals, nothing creates a more important first – and lasting – impression than the bathroom mirror. If the mirror is spotless, so too must be the rest of the space. But if the mirror shows evidence of unsightly mold and blackspot corrosion, who knows what’s lurking elsewhere in the room? Only OmegaMirror delivers years of outstanding performance that protects your property’s reputation.

INSIST ON THE MIRROR THAT PROTECTS YOUR CUSTOMERS AND THE ENVIRONMENT.

Use of lead-free, copper-free OmegaMirror reduces your ecological footprint and protects indoor air quality by emitting virtually no volatile organic compounds.



INSIST ON THE MIRROR THAT PASSES THE INDUSTRY’S MOST THOROUGH TESTING.

OmegaMirror undergoes the industry’s most rigorous, ongoing testing to ensure it meets the standard for superior performance. How do other mirrors measure up?

Test	OmegaMirror	Other Mirrors
Independent TUV CASS Test: Four complete testing cycles totaling 480 hours	✓	No
Internal CASS Test: Supplemental using Electric Mirror’s own CASS Chamber	✓	No
Acid Resistance Test: Soaked in strong acid solution for 20 hours	✓	?
Alkaline Resistance Test: Submerged in strong alkaline solution for 20 hours	✓	?
Independent UL Adhesives Test: Production adhesives applied to ensure compatibility	✓	?
Mechanical Shear Test: Mirror hanger subjected to 500 lb./square inch test to ensure backing doesn’t separate	✓	?

INSIST ON THE MIRROR THAT OFFERS THE LOWEST TOTAL COST OF OWNERSHIP.

Standard maintenance practices may necessitate replacement of bathroom mirrors every three years due to unsightly mold, black-edge, and corrosion. OmegaMirror last six times longer than standard mirror², eliminating the replacement cost in a typical renovation cycle. For a 200-room hotel, this could save \$135,000 over 10 years³. OmegaMirror not only delivers the best quality, it delivers the best value.

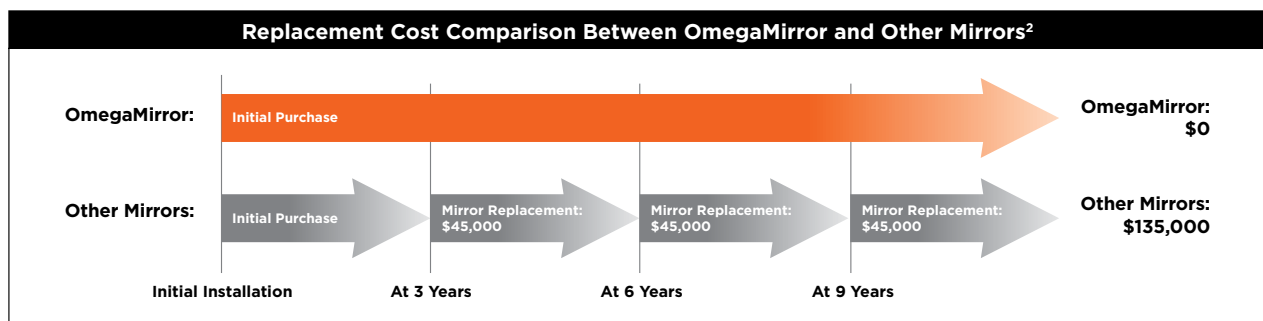

¹ The Copper Accelerated Acetic Acid Salt Spray (CASS) test is a standardized method used around the world to determine corrosion resistance of materials and coatings. CASS testing for mirrors involves placing mirror samples in a special CASS Chamber and subjecting them to a continual attack of corrosive agents that mimic a bathroom environment. The longer the samples remain corrosion free, the longer they will perform in an actual bathroom.

² Use of some glass cleaners may affect longevity. See warranty for details.

³ Mirror longevity assumes one shower per day; average U.S. shower duration is 8.2 minutes according to Alliance for Water Efficiency, 2019.

Specialized Mirror Solutions

We approach glass and mirror with the final products in mind, scientifically engineering unique solutions for optimal product performance.



Industry Standard



Diamond Clear

GLASS TECHNOLOGY

Virtually all mirror glass has a degree of subtle intrinsic color, from a pronounced green tint to nearly clear. Understanding the difference helps you select the best product for your project.



INDUSTRY STANDARD

Typical industry-standard mirrors have a slight green tint, especially noticeable around the mirror edges. The green color is caused by iron, an element necessary for the production of mirror glass. The higher the iron content, the more noticeable the green tint. This type of mirror is suitable for many applications, including recessed or framed mirrors.

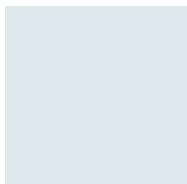

DIAMOND CLEAR

While we offer industry-standard mirror glass, some products are better suited to our Diamond Clear™ mirror. Diamond Clear has a lower iron content, which provides a whiter edge, a more natural reflection, and an ideal light color.

MIRROR TECHNOLOGY

Mirror glass used for mirror TVs has three important components to consider: mirror reflectivity, TV transmission, and TV screen area reflectivity. The environment in which the mirror TV will be used can help determine the best mirror glass option.

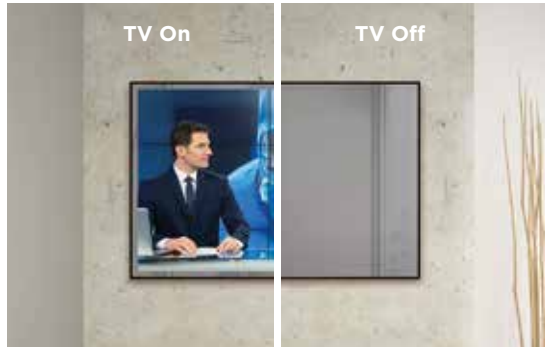

IRIS

Iris® mirror, used on our Entertainment Mirror TVs and Eclipse™ TV Covers, offers stunning quality, reduced glare, and a viewing experience close to that of a standard monitor or HDTV. The display virtually vanishes when off, leaving only a subtle, faint outline of the display perimeter that may be noticeable up close. Iris mirror is slightly darker than a typical mirror, making it ideal for guest rooms, bedrooms and living areas.

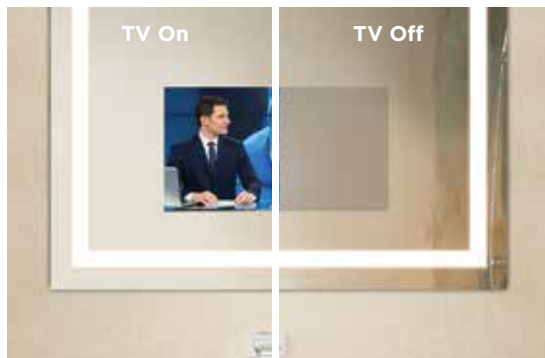

SPECTRUM

Best suited for bathrooms that are not all white or overly bright, Spectrum™ mirrors have a highly reflective mirror surface and provide a good TV image when turned on. When the TV is off, the screen area is camouflaged, leaving only a light gray image where the TV is located.

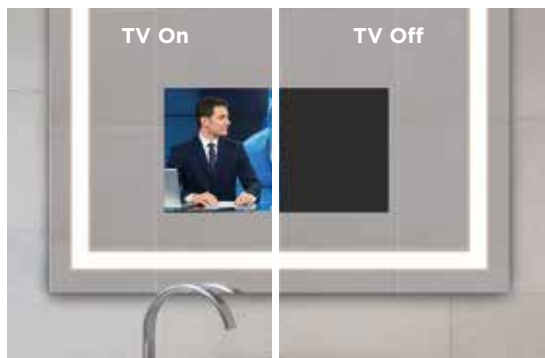

B-SERIES

Ideal for all-white or brightly colored bathrooms, B-Series™ provides a crisp, clear viewing experience with reduced glare. B-Series mirrors have a highly reflective mirror surface and an impressively bright TV image when turned on. When the TV is off, the TV screen area is black.

Exceptional LED Lighting

Understanding some of the finer points of LED lighting will help you recognize why our LEDs lead the industry.



THE HIGHEST LED STANDARD

Our dimmable, replaceable, energy-saving LEDs raise the bar on quality, color, and brightness. In fact, not only do our LEDs have the best performance, they come standard in all of our lighted mirrors, polycarbonate mirrors, lighted mirror TVs, lighted mirrored cabinets, lighted wardrobe mirrors, lighted corridor sconces, and lighted fog-free mirrors.



THE BEST COLOR TEMPERATURE

Color temperature, measured on a Kelvin (K) scale, is often an aesthetic choice. Since we know a bright, warm color is generally most flattering, we designed our mirrors with the standard light temperature of 3,000K. If you want the ability to alternate between a range of LED colors, we offer our exclusive Ava™ technology, available in many of our lighted mirror products.

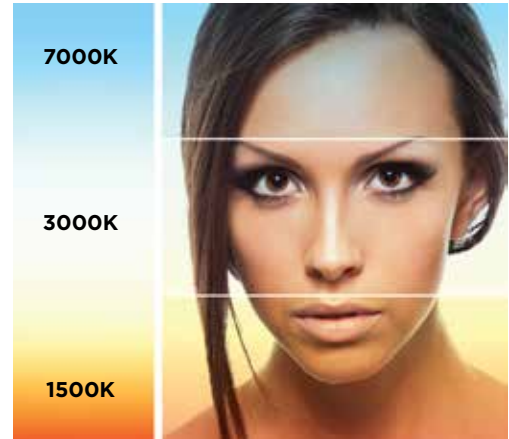

THE MOST ACCURATE LIGHT

The Color Rendering Index (CRI) is a measurement scale of how accurately a light source reflects true colors, and is expressed in a range from 0 to 100. A higher CRI indicates a more accurate color reflection. While most LED-lighted mirrors have CRIs of 80 or lower, ours boast CRIs of 90+, creating the most natural-looking color available.

THE GREATEST EFFECTIVE ILLUMINATION

Since lumen output diminishes over time, and anything less than 70% is considered insufficient, it's important to choose lighted mirrors with dependable, long-lasting LEDs. We select LEDs with a calculated L_{70} lifespan of 52,000 to 140,000 hours, easily providing many years of the best light without compromise.

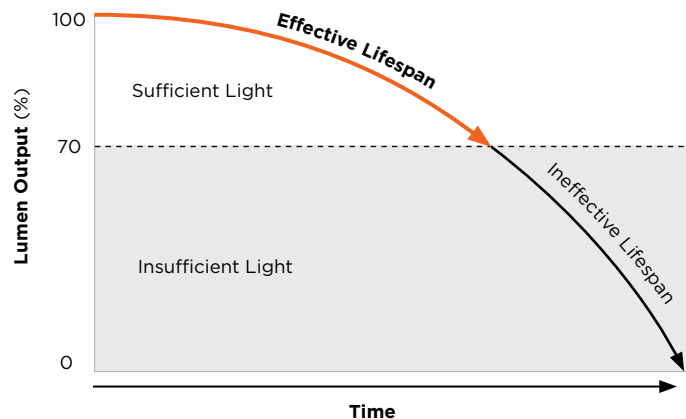

Reassuring Certifications

You can trust Electric Mirror to ensure your products are safe and meet all regulatory requirements.



**Underwriters
Laboratories**
United States



TUV Rheinland
Germany



**Federal
Communications
Commission**
United States



Intertek
United States



**Conformité
Européenne**
France



GOST
Russia



**Norma Oficial
Mexicana**
Mexico



**Regulatory
Compliance
Mark**
Australia



Title 24
California, USA



KC Certification
South Korea



**PSE
Certification**
Japan



**China
Compulsory
Certificate**
China

WE PUT SAFETY FIRST

As important as mirror aesthetics and performance are, mirror safety is even more essential. Mirror technology products must be electrically safe to withstand high voltage spikes or stray current. Mechanically safe to ensure no one is injured installing or using the product. And environmentally safe to ensure safe operating temperatures. Independent product certifications ensure our products meet these safety requirements.

WE DESIGN FOR SAFETY

Our engineers are well versed in product safety requirements, and design all of our products with electrical, mechanical, and environmental safety in mind. We work with independent experts to conduct onsite safety training presentations and demonstrations. And because we have collaborative relationships with the regulatory agencies, we're able to speak with their engineers frequently during our product design process to ensure our products are compliant.

WE MEET SAFETY STANDARDS

Every Electric Mirror product has been thoroughly evaluated by nationally-recognized testing laboratories such as UL, ULc, CE, FCC, CB Scheme, Intertek, and TUV. Our products are listed in the countries in which they're sold, meaning they're certified to the appropriate standards as required by each country's governing electrical code. In addition, our manufacturing facilities undergo unannounced quarterly follow-up inspections to verify we continue to meet or exceed all requirements.

Certifications 101

Why is testing to standards important?

Nationally Recognized Testing Laboratories (NRTL) use standardized testing to investigate materials, components, products, and systems. Having uniform standards accomplish two main objectives. First, by submitting products through a rigorous testing procedure, the standards help ensure a particular product is safe for its intended use. Second, through ongoing factory inspections, the standards ensure manufacturers continue to produce products to the appropriate safety standards.

If a manufacturer uses approved components, does that mean the overall product is approved?

Some manufacturers claim that if their product uses approved components, then the product itself is approved. This is simply not the case. Individually recognized components are tested to completely different standards than are fully manufactured products. For example, a lighted mirror may use an approved power supply, but may not have been tested as a complete assembly.

What's the risk of using products that aren't tested or approved?

Products that are not tested and certified to all of the appropriate standards may not be safe to operate. Furthermore, they are not approved for installation, risk being removed by electrical inspectors, and create exposure for possible future legal liability.

Technology



CONTENTS

76	Keen
78	Ava
80	Vive
82	Poet
84	Seamless
86	Polaris
88	Televisions
90	Hospitality TV

Keen™

Bring your lighted mirrors to life with the beauty and functionality of Keen™ Technology, which offers dimming, eco-friendly technology, and Night Glow with a touch.



THE RICHEST DIMMING EXPERIENCE

Keen's thoughtful design provides a range of light levels to satisfy every lighting need. Plus, the innovative engineering makes interacting with Keen a luxurious experience:



- The intuitive interface is seamlessly integrated into the mirror, offering a sleek and beautiful design.
- Lighting initiates at 66 percent, then brightens or dims by tapping the Keen icon.
- Night Glow mode provides just enough lighting to ensure safety when the room is dark, and the Eye-Sensitivity Adjustment technology automatically reduces the light level as eyes adjust to low light.

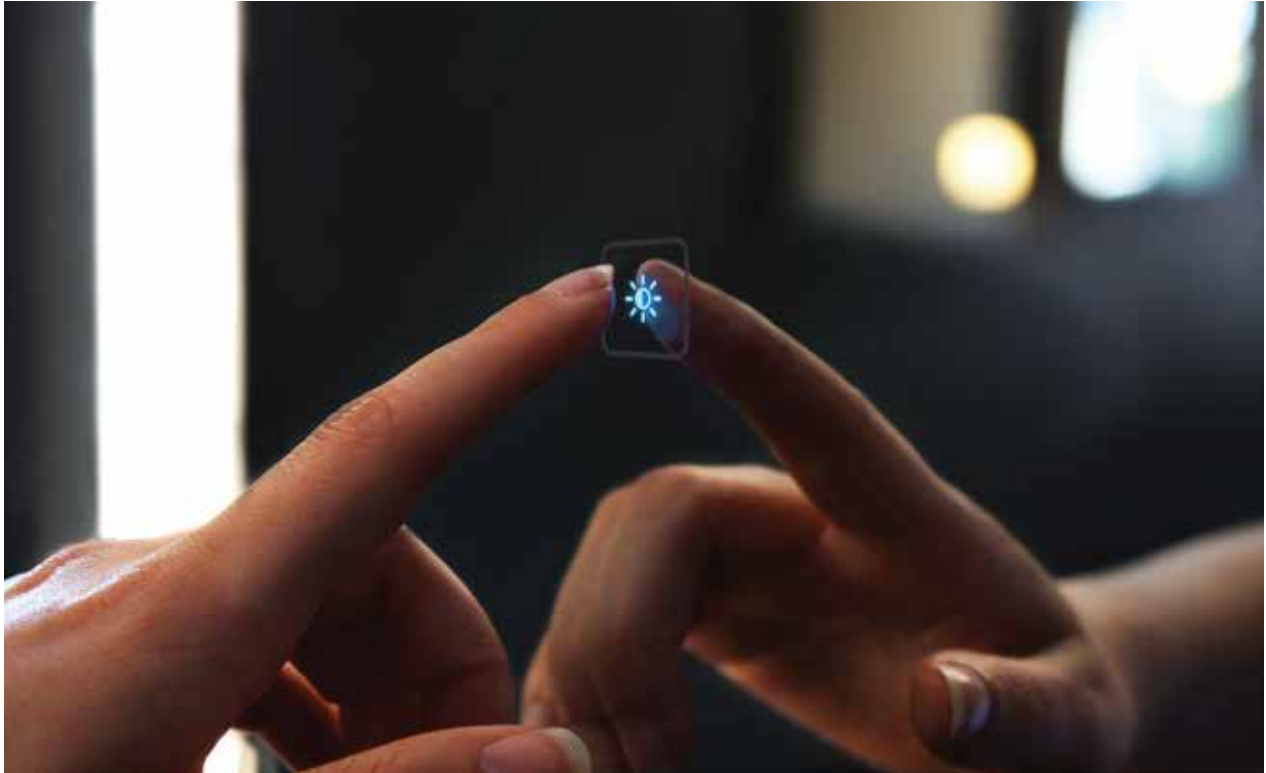

THE SMARTEST ECO-FRIENDLY TECHNOLOGY

The intelligent sensor in Keen supports your commitment to the environment:

- It automatically dims the lighted mirror to 10% after an hour of non-use.
- It helps you help the environment even if the lights are inadvertently left on.

THE EASIEST OPERATION



Tap to cycle through On at 66%, 100%, Night Glow, 25% and back to 66%.

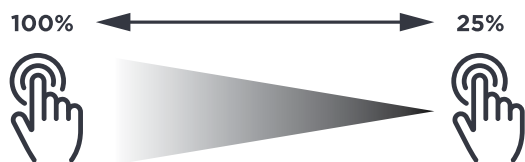

Touch and hold to gradually change light between 100% and 25% brightness.



After one hour of non-use, Keen's Energy Save Mode automatically dims the lights to 10% brightness.

Ava™

Ava™ Technology takes task lighting to a beautiful new level, allowing you to easily change the LED light color to suit your needs.



2,700K

Perfect for an early morning hike, an intimate evening dinner, or a night at the theater.



4,600K

Excellent for that important meeting in the boardroom, a busy day on campus, or a quick get-together with friends for lunch.



6,500K

Ideal for a leisurely day at the pool, 18 holes at the local country club, or a relaxing cruise.



THE IDEAL SETTINGS FOR ANY SETTING

Ava gives you the confidence to look your best in any environment. The tunable LED lights let you select the color that best matches the environment you're preparing for — outdoors, indoors, or evening, or anything in between.



THE BEAUTY OF SIMPLE INTERACTION

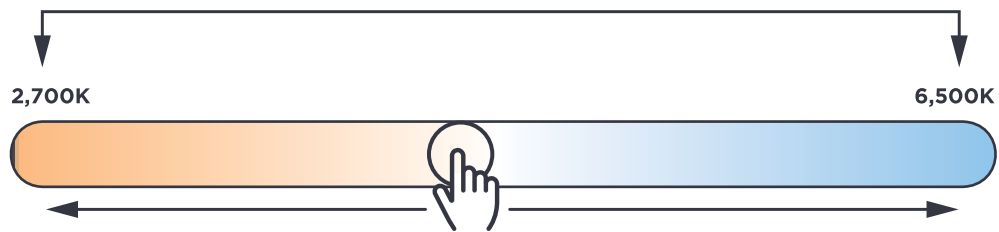

Mirror first turns on at 2,700K at full brightness. Touch and hold the Ava button to change the light color from 2,700 to 6,500K.



After one hour of non-use, Ava's Energy Save Mode automatically dims the lights to 10% brightness. Tapping the button in this state returns it to 100% brightness.



Vive®

Create a symphony of sound with Vive® Technology, which lets music from a Bluetooth® enabled device stream directly through our audio-enhanced mirrors.



VIVE IS MUSIC TO THE EYES

Fine tune lighted mirrors and wardrobe mirrors with Vive and turn any room into a virtual amphitheater. Vive pairs a Bluetooth-enabled smart phone or tablet to the mirror, instantly transforming it into a wireless stereo system. Simple and easy to use, Vive can create a symphonic streaming audio experience in any space with just a touch.



BREAK THE SOUND BARRIER WITH VIVE

Producing rich, hi-fidelity audio through the mirror's integrated speakers, and featuring an impressive 30-foot range for the Bluetooth signal, Vive is an audiophile's dream come true. And because the connection is via a Bluetooth-enabled phone or tablet, you never need to worry about a docking station taking up valuable countertop space.

VIVE MAKES IT EASY TO FACE THE MUSIC

1. Simply tap the Vive capacitive touch icon on the mirror.
2. On a Bluetooth-enabled device, select "Electric Mirror" in the Bluetooth settings. The device will be paired to the mirror when the blinking red sync light turns a solid blue.
3. Once paired, start the music via the device. Control the volume directly from the device.



Poet™

Use Poet™ Technology for a unique way to connect with people that will leave them feeling pleasantly surprised and thoroughly delighted.



COMMUNICATE IN AN ENTIRELY NEW WAY

Poet lets you inspire people with messages that unexpectedly appear, then vanish, in their mirrors. Using Poet, you can capture people's attention with poetic words, thought-provoking phrases or inspirational quotes¹.

CUSTOMIZE THE MESSAGE TO REFLECT YOUR BRAND

The Poet lets you create one, two, or even three-part messages that illuminate long enough to be read, and then vanish, returning the mirror to its original reflective state. Whatever your message, Poet brings it to life in a way that creates an indelible impression with everyone who sees it¹.



MAKE A BEAUTIFUL STATEMENT

The artistically-designed Poet message is laser etched into the back of the mirror. When the mirror is turned on, at first only the mirror lights illuminate. Then, within seconds, the messages begin to appear, each part illuminating and then vanishing in succession independent from the others. When the message sequence is complete, the mirror reverts to a traditional lighted mirror.



¹Poet model room orders require \$5K and 5 month lead time for Poet mirror. Poet production orders require \$150K in Poet mirrors and 6 month lead time.

This product is patent pending.

Seamless™

Time is on your side when you use Seamless™ Technology to embed a stunning LED clock into your lighted mirrors.



EXPERIENCE FLAWLESS TIME WITHOUT EQUAL

Innovative and convenient, the Seamless LED Clock is a must-have addition for lighted mirrors, lighted mirror TVs, and wardrobe mirrors. Featuring illuminated digits that shine through the mirror without the distraction of a clock display window, Seamless creates an image of time that flawlessly blends in with the mirror's surface.



Seamless



Other clocks

ENJOY THE BEST OF BOTH FORM AND FUNCTION

The included remote control lets the end-user easily adjust the LED brightness and alternate between 12-hour and 24-hour options.

TAKE ADVANTAGE OF SYNCHRONIZED SIMPLICITY

Seamless also offers a synchronized clock programming system, allowing you to clone settings for every mirror on the property with one adjustment.

Using the Automatic Clock Programmer handheld remote (sold separately), you can easily synchronize the clock settings with one touch of a button — ideal for time changes and new installations.

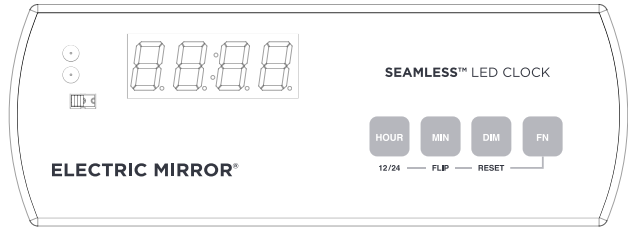

Polaris™

Like the Northern Star, our Polaris™ Technology nightlight collection offers innovative solutions to light the way.



Polaris Motion Sensor Nightlight



Polaris Wall Switch Nightlight

CONVENIENT, AFFORDABLE SOLUTIONS

The Polaris nightlight collection features energy-efficient LED nightlights that emit soft 2,200K amber-colored light. The amber color has been proven to support peaceful, uninterrupted sleep, maintaining the body's natural circadian rhythm sleep-wake cycle. However, when the need arises, the nightlights illuminate the surrounding area, supporting safer navigate around the room.

TWO WAYS TO SEE THE LIGHT

1. Polaris Motion Sensor Nightlight:

Centered along the lower edge of the mirror, this nightlight is activated by a motion detector that extends from the bottom.

- It automatically turns on when the room is mostly dark and motion is detected. The light turns off three minutes after motion is no longer detected.
- The nightlight is battery operated, and requires no additional wiring.
- The batteries recharge from the electricity that powers the lights in the mirror when the lights are turned on.

2. Polaris Wall Switch Nightlight:

Centered at the bottom of the mirror and hidden from view behind the mirror surface, the nightlight is activated by a three-way wall switch that controls the mirror lights and the nightlight.

- You have complete control over when the night light is on or off.
- This nightlight is hardwired.



Polaris Wall Switch Nightlight

Televisions

No matter what room you're focusing on — from bathrooms to living areas to public spaces — we offer TV technology to enhance the ambiance of the environment.



ENTERTAINMENT MIRROR TVS MAKE ANY LIVING SPACE MORE LUXURIENT

Any project is better when it includes the style and versatility of an entertainment mirror TV. Our design integrates a high definition LED smart TV into a superior quality wall mirror, with patented technology that allows the vibrant TV to display when on, then disappear when off.





MIRROR TVS ADD CONVENIENT FUNCTIONALITY TO THE BATHROOM

Few features add more exquisite convenience to a vanity mirror than a TV. When connected to local cable provider or favorite device such as Roku, Apple TV, Fire Box, etc., our bathroom-mirror TVs will help users better prepare for the day with timely morning weather and traffic reports, or get ready to retire for the evening while catching up on the day's headlines.

TV COVERS PUT THE FOCUS ON THE ROOM'S STYLISH DÉCOR, NOT THE TV

Our ingenious Eclipse™ TV Cover instantly transforms an existing flat-screen TV into a beautiful mirror, making the room feel larger and more sumptuous. When the TV is on, the Iris® mirror glass ensures a premium viewing experience with a bright image and reduced glare. When the TV is off, Eclipse becomes a sleek and modern mirror that magnifies and reflects the luxury of the surrounding space. Eclipse is easy and quick to install, and the universal design accommodates virtually all standard flat-screen TVs. Eclipse offers a fast, affordable and elegant way to create a more refined room.



Hospitality TV

Guests love our bathroom hospitality mirror TVs, and you'll love our Genesis II™ Technology that makes it simple to provide them with an outstanding hospitality TV experience.



THE BEST OF BOTH WORLDS

Our Hospitality TV solution provides the perfect combination of ease of use for hotel guests and ease of programming for hotel staff. When it comes to hospitality TV, only Electric Mirror can provide the features you need, the simplicity you want, and the quality you expect.

A BETTER TV VIEWING EXPERIENCE FOR YOUR GUESTS

A bathroom mirror TV offers hotel guests the ultimate luxury: access to their favorite content in the privacy of their bathroom. Offering a memorable guest experience, it creates a positive and long-lasting impression of the hotel they're sure to tell others about.



A BETTER HOSPITALITY TV SOLUTION FOR YOU

Genesis II is an innovative solution that integrates with your hospitality media management systems. Our Hospitality TV is designed to work with your IPTV set-top-box (STB) providing your guests with premium in-room entertainment and a great hospitality experience.¹

HOSPITALITY FEATURES YOU CAN OFFER YOUR GUESTS WITH IPTV SOLUTIONS¹

In-Room Entertainment

Provide guests with their favorite movies, streaming content, music and free-to-guest programming.

Hotel Marketing

Display your hotel logo, on-screen directory or in-house ads to provide your guests with reminders of everything your property has to offer.

Guest Info

Provide flight data, local weather, in-room dining and other guest-requested items such as extra pillows.

Channel Mapping

Eliminate confusion and give your guests the same channel line-up in the bathroom as in the guestroom, including channel skipping and blocking.

Volume Control

Set your preferred minimum and maximum volume levels to help minimize disturbance to other hotel guests.

Waterproof Remote

Make TV control simple for guests with our buoyant waterproof guest remote.



PRODUCT FEATURES WE CAN OFFER YOU

Superior Mirror TV

Our Mirror TVs feature OmegaMirror™ anti-corrosion mirror, state-of-the-art integrated speakers, HDMI, HDMI (CEC), USB, RS232, and IR pass-through controls, and comprehensive safety standards compliance.

Exceptional TV Display

Enjoy your choice of a 15.6" or 21.5" ultra-slim 1" TV featuring an LED HDTV high-bright panel, 1920 x 1080 resolution, a 16:9 true wide screen ratio, and a 50,000 hour product life.

¹Requires Set Top Box, neither included nor programmed by Electric Mirror.

Products



CONTENTS

94	Lighted Mirrors
132	Polycarbonate Mirrors
140	Mirror TVs
156	TV Covers
160	Mirrored Cabinets
168	Makeup Mirrors
186	Wardrobe Mirrors
192	Fog-Free Mirrors
198	Corridor Lighting
206	Framed Mirrors
210	UVC Disinfection
220	New Products



LIGHTED MIRRORS



Roman Colosseum
Rome, Italy

Aria™ Lighted Mirror

The Aria™ offers a delicate dichotomy of design for any project requiring a unique new look: the romantic curves of rounded corners combined with the exacting look of a symmetrical inset border of light.

DIMENSIONS

- 24"W x 36"H (610mm x 914mm)
- 36"W x 36"H (914mm x 914mm)
- 48"W x 36"H (1219mm x 914mm)
- 60"W x 36"H (1524mm x 914mm)

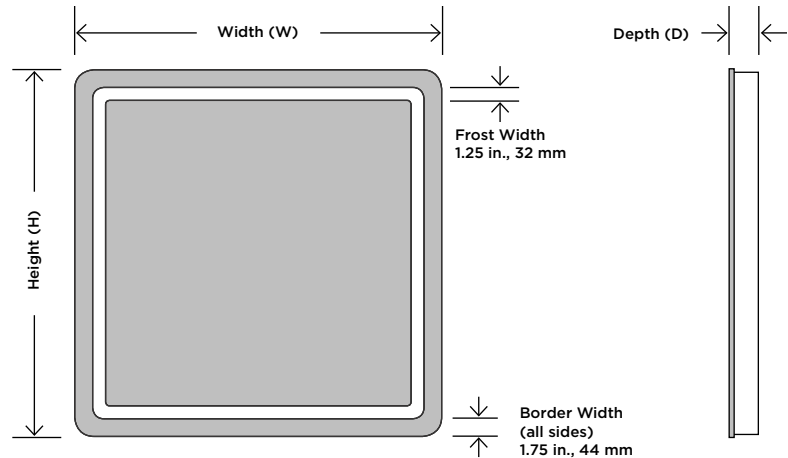

FEATURES AND BENEFITS

- Lead-free, copper-free, corrosion-resistant OmegaMirror™ glass
- Forward-facing task lighting
- Suitable for damp bathroom environments
- Environmentally sustainable
- Energy efficient
- Fast lead times
- Easy installation
- Title 24 compliance available
- 10-year limited warranty
- Covered by one or more patents
- Made in America with U.S. and global components

AVAILABLE OPTIONS

- Ava™ Technology^{1,2}
- Keen™ Technology²
- Polaris™ Technology^{1,2}
- Seamless™ Technology^{1,2}
- Vive™ Technology^{1,2}
- Defogger
- CCT: 2,700K
- 0-10V dimming
- Forward-phase dimming
- 277V available³
- Custom sizes

LIGHTING SPECIFICATIONS

- Natural-looking LED light color
- CRI: 90+
- CCT: 3,000 Kelvin
- Replaceable LEDs
- 604 lumens per foot
- Maximum 100 lumens per watt efficacy
- Calculated L₇₀ 124,000-hour LED lifespan

SAFETY SPECIFICATIONS

- Entire assembly meets UL/cUL standards
- International certifications
- Safety-backed mirror

INSTALLATION SPECIFICATIONS

- 120V-240V hardwire electrical connection; provide 36" whip; junction box not required
- Chassis should be mounted to wall studs; mounting holes are provided
- Controlled by non-dimming on/off wall switch
- Installation wiring may be different on mirrors equipped with additional options
- Fixture can only be hung in the WxH orientation as shown; fixture is not field-interchangeable

¹ Minimum order quantity required.

² See technology specification sheets for more details.

³ May not be compatible with all upgrades and options.



Bela™ Lighted Mirror

Add contemporary flair to your design with the distinctive radius corners and slim frost windows of the Bela™. Featuring a smooth polished edge and rounded bands of light, this mirror is as artful as it is alluring.

DIMENSIONS

- 24"W x 42"H (610mm x 1067mm)
- 36"W x 42" (914mm x 1067mm)
- 48"W x 42"H (1219mm x 1067mm)
- 60"W x 42"H (1524mm x 1067mm)

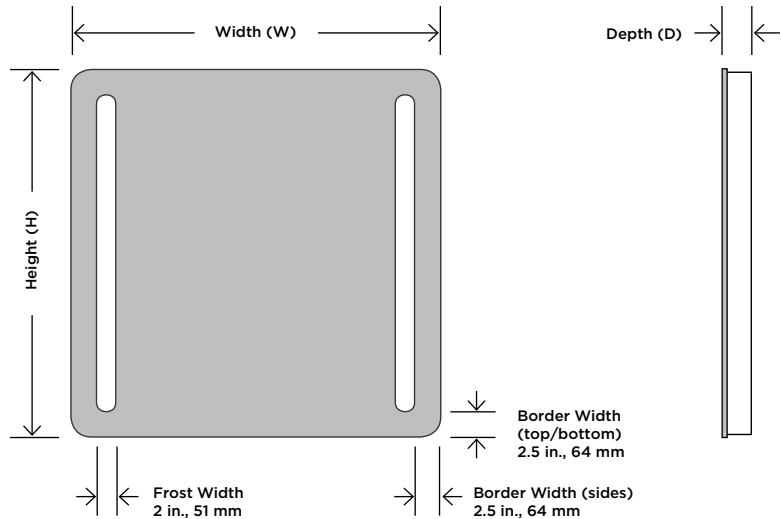

FEATURES AND BENEFITS

- Lead-free, copper-free, corrosion-resistant OmegaMirror™ glass
- Forward-facing task lighting
- Suitable for damp bathroom environments
- Environmentally sustainable
- Energy efficient
- Fast lead times
- Easy installation
- ADA compliant
- Title 24 compliance available
- 10-year limited warranty
- Covered by one or more patents
- Made in America with U.S. and global components

AVAILABLE OPTIONS

- Ava™ Technology^{1,2}
- Keen™ Technology²
- Polaris™ Technology^{1,2}
- Seamless™ Technology^{1,2}
- Vive™ Technology^{1,2}
- Defogger
- CCT: 2,700K
- 0-10V dimming
- Forward-phase dimming
- 277V available³
- Custom sizes

LIGHTING SPECIFICATIONS

- Natural-looking LED light color
- CRI: 90+
- CCT: 3,000 Kelvin
- Replaceable LEDs
- 604 lumens per foot
- Maximum 100 lumens per watt efficacy
- Calculated L₇₀ 124,000-hour LED lifespan

SAFETY SPECIFICATIONS

- Entire assembly meets UL/cUL standards
- International certifications
- Safety-backed mirror

INSTALLATION SPECIFICATIONS

- 120V-240V hardwire electrical connection; provide 36" whip; junction box not required
- Chassis should be mounted to wall studs; mounting holes are provided
- Controlled by non-dimming on/off wall switch
- Installation wiring may be different on mirrors equipped with additional options
- Fixture can only be hung in the WxH orientation as shown; fixture is not field-interchangeable

¹ Minimum order quantity required.

² See technology specification sheets for more details.

³ May not be compatible with all upgrades and options.



Brilliance™ Lighted Mirror

Combining a timeless, balanced shape with inward-facing directional lighting is sheer Brilliance™. The front-lit design of this modern, slim-profile mirror elevates task lighting to level never before seen.

DIMENSIONS

- 30" diameter (762mm)
- 36" diameter (914mm)
- 24"W x 36"H (610mm x 914mm)

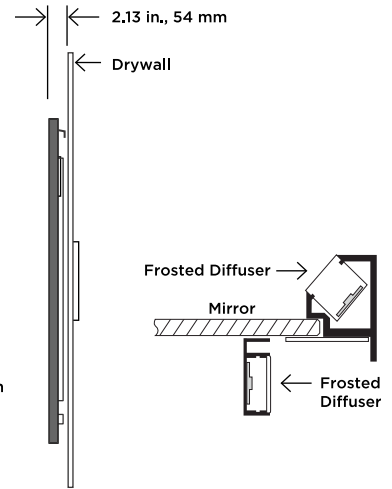
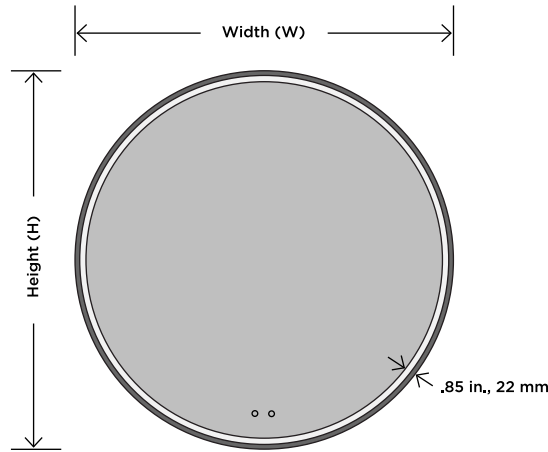

FEATURES AND BENEFITS

- Lead-free, copper-free, corrosion-resistant OmegaMirror™ glass
- One-touch dimmable inward-facing task lighting for brilliant facial illumination
- One-touch dimmable wall-glow ambient lighting with diffuser for a finished side view
- Greater illuminance with half the power consumption of traditional LED mirrors
- Sleek and modern profile
- Suitable for damp bathroom environments
- Environmentally sustainable
- Energy efficient
- Easy installation
- Title 24 compliance available
- 10-year limited warranty
- Patent pending
- Designed in the USA

AVAILABLE OPTIONS

- Clock^{1,2}
- Defogger¹
- 0-10V dimming¹
- Matte black finish standard; other finishes available¹
- 220V available^{1,3}
- Custom sizes¹

LIGHTING SPECIFICATIONS

- Natural-looking LED light color
- CRI: 90+
- CCT: 3,000 Kelvin
- 252 lumens per foot (front light)
- 468 lumens per foot (wall glow)
- Maximum 100 lumens per watt efficacy
- Calculated L₇₀ 36,000-hour LED lifespan
- Built-in EMX diffusers

SAFETY SPECIFICATIONS

- Entire assembly meets UL/cUL standards
- Safety-backed mirror

INSTALLATION SPECIFICATIONS

- 120V hardwire electrical connection; junction box required
- Fixture should be mounted to wall studs; wall cleat provided
- Controlled by non-dimming wall switch for on/off, and capacitive touch button on fixture for dimming
- Installation wiring may be different on mirrors equipped with additional options
- Fixture can only be hung in the WxH orientation as shown; fixture is not field-interchangeable

¹ Minimum order quantity required.

² See technology specification sheets for more details.

³ May not be compatible with all upgrades and options.



Element™ Lighted Mirror

Every modern space could use an eye-catching Element™ to emphasize the room's contemporary décor. Secured to the ceiling by a stainless steel frame and featuring two vertical bands of pure, natural-looking light, this urbane design balances great looks with lasting performance.

DIMENSIONS

Mirror Dimensions

- 24.25"W x 38.38"H (616mm x 975mm)

Assembly Height

- 60"H (1524mm)
- 72"H (1829mm)

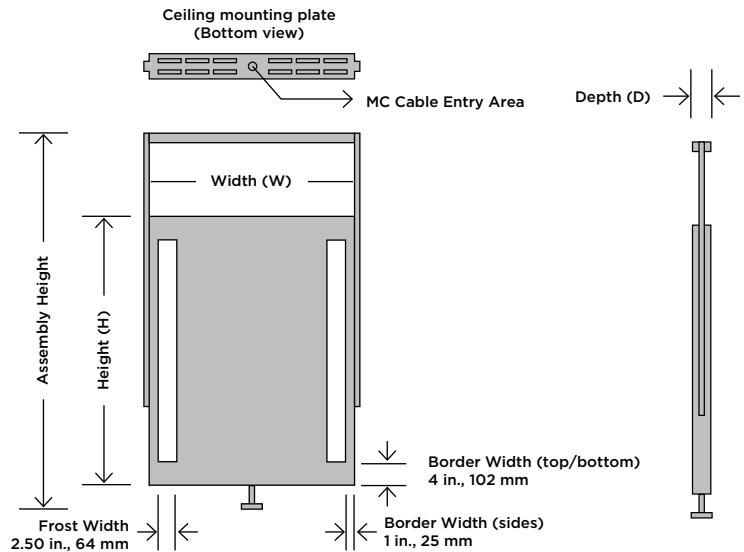

FEATURES AND BENEFITS

- Lead-free, copper-free, corrosion-resistant OmegaMirror™ glass
- Forward-facing task lighting
- Full mirror on reverse side
- Suitable for damp bathroom environments
- Environmentally sustainable
- Energy efficient
- Fast lead times
- Easy installation
- ADA compliant
- Title 24 compliance available
- 10-year limited warranty
- Covered by one or more patents
- Made in America with U.S. and global components

AVAILABLE OPTIONS

- Keen™ Technology^{1,2}
- Seamless™ Technology^{1,2}
- Defogger
- CCT: 2,700K
- 0-10V dimming
- Forward-phase dimming
- 277V available³
- Polished stainless-steel finish standard; brushed stainless-steel finish available

LIGHTING SPECIFICATIONS

- Natural-looking LED light color
- CRI: 90+
- CCT: 3,000 Kelvin
- Replaceable LEDs
- 604 lumens per foot
- Maximum 100 lumens per watt efficacy
- Calculated L₇₀ 124,000-hour LED lifespan

¹ Minimum order quantity required.

² See technology specification sheets for more details.

³ May not be compatible with all upgrades and options.

SAFETY SPECIFICATIONS

- Entire assembly meets UL/cUL standards
- International certifications
- Safety-backed mirror

INSTALLATION SPECIFICATIONS

- 120V-240V hardwire electrical connection; provide 12" whip; junction box not required
- Power to fixture supplied with MC cable exiting ceiling and entering through chassis knockout
- Fixture is ceiling mounted either 60" or 72" above countertop; ceiling must be sufficient in strength to handle weight of entire fixture
- Includes multiple ceiling mounting slots and counter mounted anchor
- Controlled by non-dimming on/off wall switch
- Installation wiring may be different on mirrors equipped with additional options
- Fixture can only be hung in the WxH orientation as shown; fixture is not field-interchangeable



Eminence™ Lighted Mirror

This lighted mirror has risen to a place of Eminence™ among designers, bringing prestige and distinction to every room it graces. A unique shadow-box frame, inward-facing task lighting, and ambient wall glow combine to create a perfect balance of form and function.

DIMENSIONS

- 24"W x 36"H
(601mm x 914mm)
- 30"W x 42"H
(762mm x 1067mm)

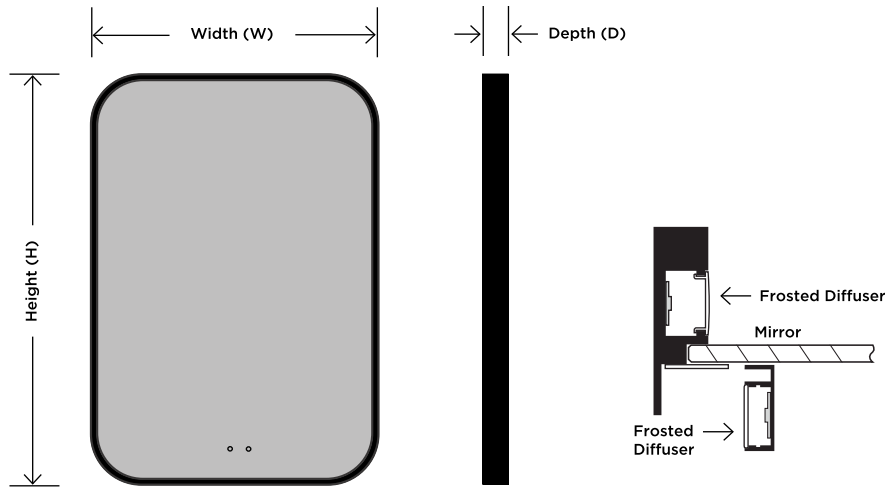

FEATURES AND BENEFITS

- Lead-free, copper-free, corrosion-resistant OmegaMirror™ glass
- One-touch dimmable inward-facing task lighting for brilliant facial illumination
- One-touch dimmable wall-glow ambient lighting with diffuser for a finished side view
- Greater illuminance with half the power consumption of traditional LED mirrors
- Sleek and modern profile
- Suitable for damp bathroom environments
- Environmentally sustainable
- Energy efficient
- Easy installation
- Title 24 compliance available
- 10-year limited warranty
- Patent pending
- Designed in the USA

AVAILABLE OPTIONS

- Clock^{1,2}
- Defogger¹
- 0-10V dimming¹
- Matte black finish standard; other finishes available¹
- 220V available^{1,3}
- Custom sizes¹

LIGHTING SPECIFICATIONS

- Natural-looking LED light color
- CRI: 90+
- CCT: 3,000 Kelvin (appears as 2,900K after diffusion)
- 252 lumens per foot (front light)
- 468 lumens per foot (wall glow)
- Maximum 100 lumens per watt efficacy
- Calculated L₇₀ 36,000-hour LED lifespan
- Built-in EMX diffusers

SAFETY SPECIFICATIONS

- Entire assembly meets UL/cUL standards
- Safety-backed mirror

INSTALLATION SPECIFICATIONS

- 120V hardwire electrical connection; junction box required
- Fixture should be mounted to wall studs; wall cleat provided
- Controlled by non-dimming wall switch for on/off, and capacitive touch button on fixture for dimming
- Installation wiring may be different on mirrors equipped with additional options
- Fixture can only be hung in the WxH orientation as shown; fixture is not field-interchangeable

¹ Minimum order quantity required.

² See technology specification sheets for more details.

³ May not be compatible with all upgrades and options.



Eternity™ Lighted Mirror

By uniting a romantic shape with a stunning circle of brilliant light, we created an Eternity™ that encapsulates a clear vision of renewal and balance, boldly illuminating your space with timeless elegance.

DIMENSIONS

- 21"W x 30"H (Oval)
(533mm x 762mm)
- 30" diameter (762mm)
- 36" diameter (914mm)

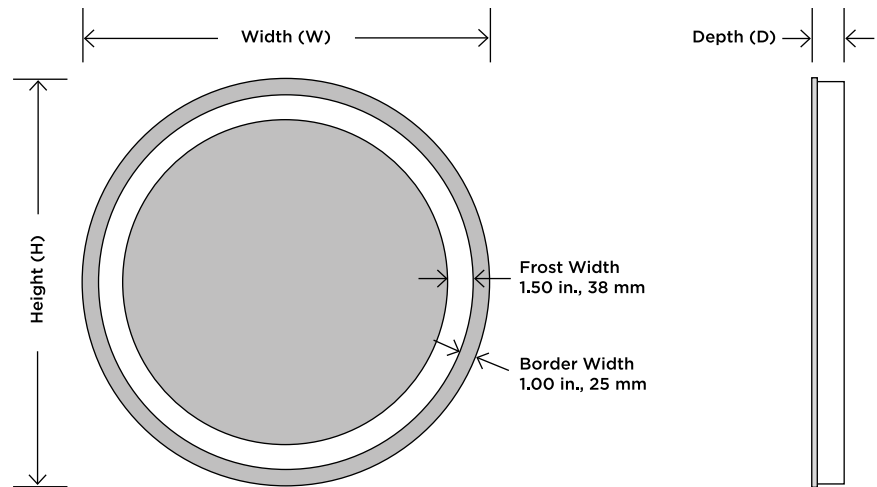

FEATURES AND BENEFITS

- Lead-free, copper-free, corrosion-resistant OmegaMirror™ glass
- Forward-facing task lighting
- Enclosed chassis
- Suitable for damp bathroom environments
- Environmentally sustainable
- Energy efficient
- Fast lead times
- Easy installation
- Title 24 compliance available
- 10-year limited warranty
- Covered by one or more patents
- Made in America with U.S. and global components

AVAILABLE OPTIONS

- Ava™ Technology^{1,2}
- Keen™ Technology²
- Polaris™ Technology^{1,2}
- Seamless™ Technology^{1,2}
- Vive™ Technology^{1,2}
- Defogger
- CCT: 2,700K
- 0-10V dimming
- Forward-phase dimming
- 277V available³
- Custom sizes

LIGHTING SPECIFICATIONS

- Natural-looking LED light color
- CRI: 90+
- CCT: 3,000 Kelvin
- Replaceable LEDs
- 604 lumens per foot
- Maximum 100 lumens per watt efficacy
- Calculated L₇₀ 124,000-hour LED lifespan

SAFETY SPECIFICATIONS

- Entire assembly meets UL/cUL standards
- International certifications
- Safety-backed mirror

INSTALLATION SPECIFICATIONS

- 120V-240V hardwire electrical connection; provide 36" whip; junction box not required
- Chassis should be mounted to wall studs; mounting holes are provided
- Controlled by non-dimming on/off wall switch
- Installation wiring may be different on mirrors equipped with additional options
- Fixture can only be hung in the WxH orientation as shown; fixture is not field-interchangeable

¹ Minimum order quantity required.

² See technology specification sheets for more details.

³ May not be compatible with all upgrades and options.



Eyla™ Lighted Mirror

Bring soothing tranquility to any space with the gentle curves and radiant wall glow of the Eyla™. Combining practical task lighting with subdued ambiance, this mirror offers blissful balance for any project.

DIMENSIONS

- 24"W x 36"H (610mm x 914mm)
- 36"W x 36"H (914mm x 914mm)
- 48"W x 36"H (1219mm x 914mm)
- 60"W x 36"H (1524mm x 914mm)

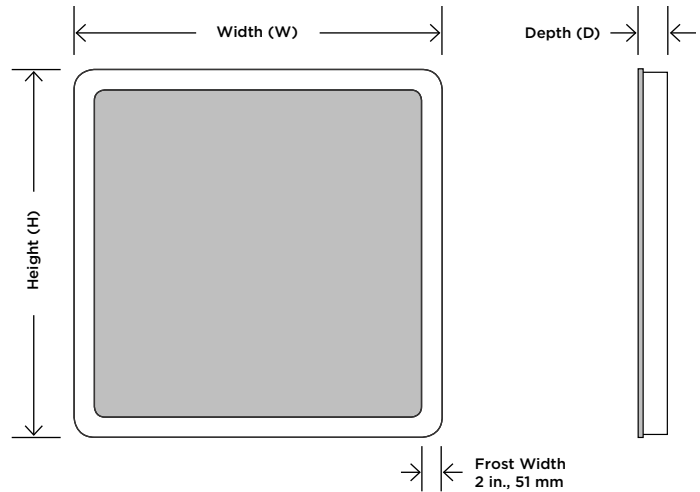

FEATURES AND BENEFITS

- Lead-free, copper-free, corrosion-resistant OmegaMirror™ glass
- Forward-facing task lighting
- Wall-glow ambient lighting on all four sides with diffuser for a finished side view
- Suitable for damp bathroom environments
- Environmentally sustainable
- Energy efficient
- Fast lead times
- Easy installation
- Title 24 compliance available
- 10-year limited warranty
- Covered by one or more patents
- Made in America with U.S. and global components

AVAILABLE OPTIONS

- Ava™ Technology^{1,2}
- Keen™ Technology²
- Polaris™ Technology^{1,2}
- Seamless™ Technology^{1,2}
- Vive™ Technology^{1,2}
- Defogger
- CCT: 2,700K
- 0-10V dimming
- Forward-phase dimming
- 277V available³
- Custom sizes

LIGHTING SPECIFICATIONS

- Natural-looking LED light color
- CRI: 90+
- CCT: 3,000 Kelvin
- Replaceable LEDs
- 720 lumens per foot
- Maximum 100 lumens per watt efficacy
- Calculated L₇₀ 52,000-hour LED lifespan

SAFETY SPECIFICATIONS

- Entire assembly meets UL/cUL standards
- International certifications
- Safety-backed mirror

INSTALLATION SPECIFICATIONS

- 120V-240V hardwire electrical connection; provide 36" whip; junction box not required
- Chassis should be mounted to wall studs; mounting holes are provided
- Controlled by non-dimming on/off wall switch
- Installation wiring may be different on mirrors equipped with additional options
- Fixture can only be hung in the WxH orientation as shown; fixture is not field-interchangeable

¹ Minimum order quantity required.

² See technology specification sheets for more details.

³ May not be compatible with all upgrades and options.



Fusion™ Lighted Mirror

The ideal Fusion™ comes from a definitive combination of clean, strong lines and efficient, natural-looking LED lighting – adding a distinctly modern statement of prestige to your bathroom.

DIMENSIONS

- 24"W x 36"H (610mm x 914mm)
- 36"W x 36"H (914mm x 914mm)
- 48"W x 36"H (1219mm x 914mm)
- 60"W x 36"H (1524mm x 914mm)

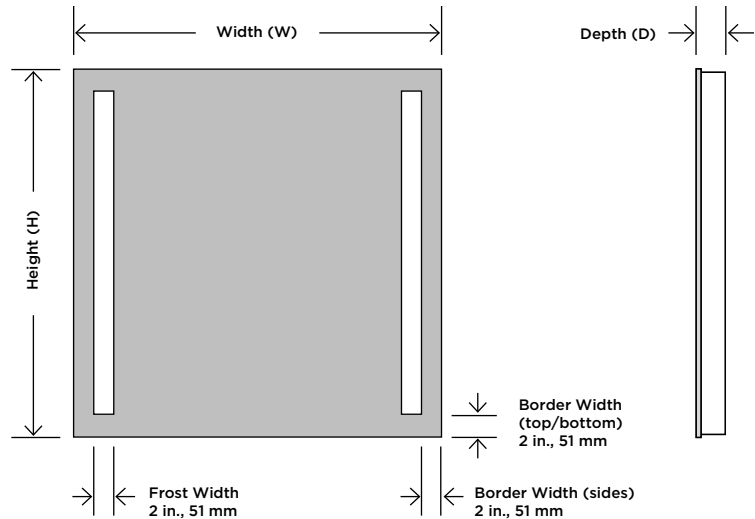

FEATURES AND BENEFITS

- Lead-free, copper-free, corrosion-resistant OmegaMirror™ glass
- Forward-facing task lighting
- Suitable for damp bathroom environments
- Environmentally sustainable
- Energy efficient
- Fast lead times
- Easy installation
- ADA compliant
- Title 24 compliance available
- 10-year limited warranty
- Covered by one or more patents
- Made in America with U.S. and global components

AVAILABLE OPTIONS

- Ava™ Technology^{1,2}
- Keen™ Technology²
- Polaris™ Technology^{1,2}
- Seamless™ Technology^{1,2}
- Vive™ Technology^{1,2}
- Defogger
- CCT: 2,700K
- 0-10V dimming
- Forward-phase dimming
- 277V available³
- Custom sizes

LIGHTING SPECIFICATIONS

- Natural-looking LED light color
- CRI: 90+
- CCT: 3,000 Kelvin
- Replaceable LEDs
- 604 lumens per foot
- Maximum 100 lumens per watt efficacy
- Calculated L₇₀ 124,000-hour LED lifespan

SAFETY SPECIFICATIONS

- Entire assembly meets UL/cUL standards
- International certifications
- Safety-backed mirror

INSTALLATION SPECIFICATIONS

- 120V-240V hardwire electrical connection; provide 36" whip; junction box not required
- Chassis should be mounted to wall studs; mounting holes are provided
- Controlled by non-dimming on/off wall switch
- Installation wiring may be different on mirrors equipped with additional options
- Fixture can only be hung in the WxH orientation as shown; fixture is not field-interchangeable

¹ Minimum order quantity required.

² See technology specification sheets for more details.

³ May not be compatible with all upgrades and options.



Integrity™ Lighted Mirror

Add glimmering light and tasteful grace to any space with a powerful impression of Integrity™. Featuring a smooth polished edge and brilliant inner frame of frosted light, this radiant marvel is as stylish as it is functional.

DIMENSIONS

- 24"W x 36"H (610mm x 914mm)
- 30"W x 42"H (762mm x 1067mm)
- 36"W x 36"H (914mm x 914mm)
- 42"W x 42"H (1067mm x 1067mm)
- 48"W x 36"H (1219mm x 914mm)
- 54"W x 42"H (1372mm x 1067mm)
- 60"W x 36"H (1524mm x 914mm)
- 66"W x 42"H (1676mm x 1067mm)

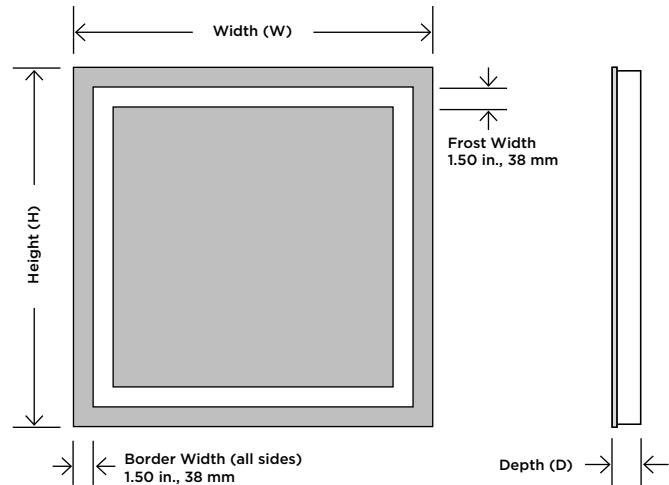

FEATURES AND BENEFITS

- Lead-free, copper-free, corrosion-resistant OmegaMirror™ glass
- Forward-facing task lighting
- Suitable for damp bathroom environments
- Environmentally sustainable
- Energy efficient
- Fast lead times
- Easy installation
- Title 24 compliance available
- 10-year limited warranty
- Covered by one or more patents
- Made in America with U.S. and global components

AVAILABLE OPTIONS

- Ava™ Technology^{1,2}
- Keen™ Technology²
- Polaris™ Technology^{1,2}
- Seamless™ Technology^{1,2}
- Vive™ Technology^{1,2}
- Defogger
- CCT: 2,700K
- 0-10V dimming
- Forward-phase dimming
- 277V available³
- Custom sizes

LIGHTING SPECIFICATIONS

- Natural-looking LED light color
- CRI: 90+
- CCT: 3,000 Kelvin
- Replaceable LEDs
- 604 lumens per foot
- Maximum 100 lumens per watt efficacy
- Calculated L₇₀ 124,000-hour LED lifespan

SAFETY SPECIFICATIONS

- Entire assembly meets UL/cUL standards
- International certifications
- Safety-backed mirror

INSTALLATION SPECIFICATIONS

- 120V-240V hardwire electrical connection; provide 36" whip; junction box not required
- Chassis should be mounted to wall studs; mounting holes are provided
- Controlled by non-dimming on/off wall switch
- Installation wiring may be different on mirrors equipped with additional options
- Fixture can only be hung in the WxH orientation as shown; fixture is not field-interchangeable

¹ Minimum order quantity required.

² See technology specification sheets for more details.

³ May not be compatible with all upgrades and options.



Momentum™ Lighted Mirror

Add Momentum™ to your room's décor for a look that flawlessly marries high-tech with tasteful design. Paring a brilliant inner band of frosted light with a sleek and modern frame, this stunning centerpiece makes a welcome addition to bedrooms and bathrooms.

DIMENSIONS

- 29"W x 41"H (737mm x 1041mm)
- 41"W x 41"H (1041mm x 1041mm)
- 53"W x 41"H (1346mm x 1041mm)
- 65"W x 41"H (1651mm x 1041mm)

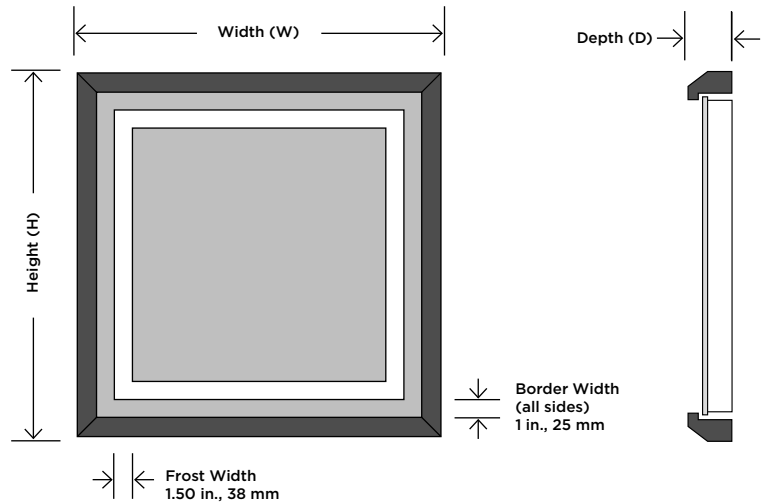

FEATURES AND BENEFITS

- Lead-free, copper-free, corrosion-resistant OmegaMirror™ glass
- Forward-facing task lighting
- Suitable for damp bathroom environments
- Environmentally sustainable
- Energy efficient
- Fast lead times
- Easy installation
- Title 24 compliance available
- 10-year limited warranty
- Covered by one or more patents
- Made in America with U.S. and global components

AVAILABLE OPTIONS

- Ava™ Technology^{1,2}
- Keen™ Technology²
- Polaris™ Technology^{1,2}
- Seamless™ Technology^{1,2}
- Vive™ Technology^{1,2}
- Defogger
- CCT: 2,700K
- 0-10V dimming
- Forward-phase dimming
- 277V available³
- Urban Profile frame ebony finish standard; other finishes available
- Custom frames¹
- Custom sizes

LIGHTING SPECIFICATIONS

- Natural-looking LED light color
- CRI: 90+
- CCT: 3,000 Kelvin
- Replaceable LEDs
- 604 lumens per foot
- Maximum 100 lumens per watt efficacy
- Calculated L₇₀ 124,000-hour LED lifespan

SAFETY SPECIFICATIONS

- Entire assembly meets UL/cUL standards
- International certifications
- Safety-backed mirror

INSTALLATION SPECIFICATIONS

- 120V-240V hardwire electrical connection; provide 36" whip; junction box not required
- Chassis should be mounted to wall studs; mounting holes are provided
- Controlled by non-dimming on/off wall switch
- Installation wiring may be different on mirrors equipped with additional options
- Fixture can only be hung in the WxH orientation as shown; fixture is not field-interchangeable

¹ Minimum order quantity required.

² See technology specification sheets for more details.

³ May not be compatible with all upgrades and options.



Novo™ Lighted Mirror

A singularly smart and modern alternative to bathroom sconces, Novo™ pairs incredible natural-looking illumination with ultra-soft wall glow, forming a harmonious combination of task and ambiance lighting.

DIMENSIONS

- 24"W x 36"H (610mm x 914mm)
- 36"W x 36"H (914mm x 914mm)
- 48"W x 36"H (1219mm x 914mm)
- 60"W x 36"H (1524mm x 914mm)

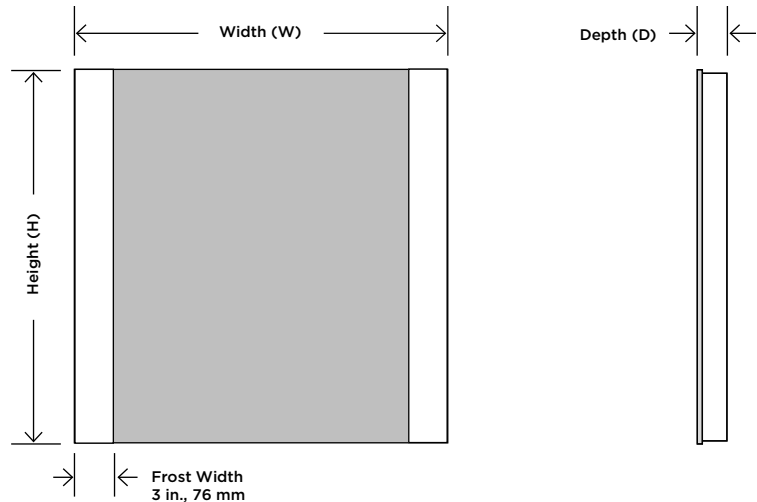

FEATURES AND BENEFITS

- Lead-free, copper-free, corrosion-resistant OmegaMirror™ glass
- Forward-facing task lighting
- Wall-glow ambient lighting on left and right side with diffuser for a finished side view
- Suitable for damp bathroom environments
- Environmentally sustainable
- Energy efficient
- Fast lead times
- Easy installation
- ADA compliant
- Title 24 compliance available
- 10-year limited warranty
- Covered by one or more patents
- Made in America with U.S. and global components

AVAILABLE OPTIONS

- Ava™ Technology^{1,2}
- Keen™ Technology²
- Polaris™ Technology^{1,2}
- Seamless™ Technology^{1,2}
- Vive™ Technology^{1,2}
- Defogger
- CCT: 2,700K
- 0-10V dimming
- Forward-phase dimming
- 277V available³
- Custom sizes

LIGHTING SPECIFICATIONS

- Natural-looking LED light color
- CRI: 90+
- CCT: 3,000 Kelvin
- Replaceable LEDs
- 720 lumens per foot
- Maximum 100 lumens per watt efficacy
- Calculated L₇₀ 52,000-hour LED lifespan

SAFETY SPECIFICATIONS

- Entire assembly meets UL/cUL standards
- International certifications
- Safety-backed mirror

INSTALLATION SPECIFICATIONS

- 120V-240V hardwire electrical connection; provide 36" whip; junction box not required
- Chassis should be mounted to wall studs; mounting holes are provided
- Controlled by non-dimming on/off wall switch
- Installation wiring may be different on mirrors equipped with additional options
- Fixture can only be hung in the WxH orientation as shown; fixture is not field-interchangeable

¹ Minimum order quantity required.

² See technology specification sheets for more details.

³ May not be compatible with all upgrades and options.



Novo™ with Wall Glow Lighted Mirror

A favorite among designers, architects and users, this Novo™ features forward-facing task lighting combined with a halo of soft, ambient light on all four sides, eliminating the need for additional vanity lighting.

DIMENSIONS

- 30"W x 42"H (762mm x 1067mm)
- 36"W x 42"H (914mm x 1067mm)
- 48"W x 42"H (1219mm x 1067mm)
- 60"W x 42"H (1524mm x 1067mm)

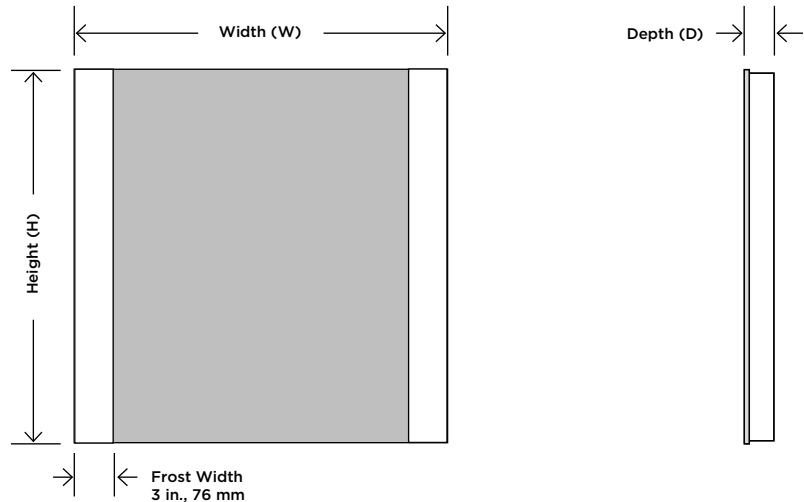

FEATURES AND BENEFITS

- Lead-free, copper-free, corrosion-resistant OmegaMirror™ glass
- Forward-facing task lighting
- Wall-glow ambient lighting on all four sides with diffuser for a finished side view
- Suitable for damp bathroom environments
- Environmentally sustainable
- Energy efficient
- Fast lead times
- Easy installation
- ADA compliant
- Title 24 compliance available
- 10-year limited warranty
- Covered by one or more patents
- Made in America with U.S. and global components

AVAILABLE OPTIONS

- Ava™ Technology^{1,2}
- Keen™ Technology²
- Polaris™ Technology^{1,2}
- Seamless™ Technology^{1,2}
- Vive™ Technology^{1,2}
- Defogger
- CCT: 2,700K
- 0-10V dimming
- Forward-phase dimming
- 277V available³
- Custom sizes

LIGHTING SPECIFICATIONS

- Natural-looking LED light color
- CRI: 90+
- CCT: 3,000 Kelvin
- Replaceable LEDs
- 720 lumens per foot
- Maximum 100 lumens per watt efficacy
- Calculated L₇₀ 52,000-hour LED lifespan

SAFETY SPECIFICATIONS

- Entire assembly meets UL/cUL standards
- International certifications
- Safety-backed mirror

INSTALLATION SPECIFICATIONS

- 120V-240V hardwire electrical connection; provide 36" whip; junction box not required
- Chassis should be mounted to wall studs; mounting holes are provided
- Controlled by non-dimming on/off wall switch
- Installation wiring may be different on mirrors equipped with additional options
- Fixture can only be hung in the WxH orientation as shown; fixture is not field-interchangeable

¹ Minimum order quantity required.

² See technology specification sheets for more details.

³ May not be compatible with all upgrades and options.



Novo-4™ Lighted Mirror

Offering natural-looking LED light for the vanity and ceiling, while bathing the room with radiant wall-glow light, the Novo-4™ provides a novel approach to both form and function.

DIMENSIONS

- 30"W x 36"H (762mm x 914mm)
- 36"W x 36"H (914mm x 914mm)
- 48"W x 36"H (1219mm x 914mm)
- 60"W x 36"H (1524mm x 914mm)

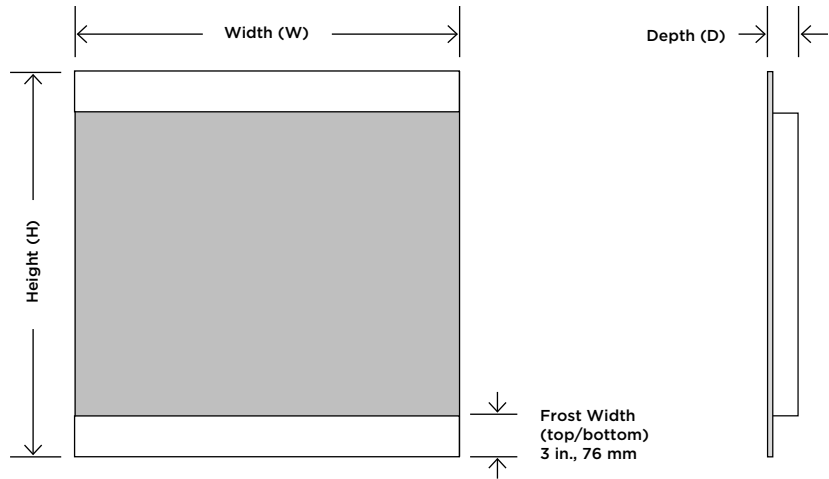

FEATURES AND BENEFITS

- Lead-free, copper-free, corrosion-resistant OmegaMirror™ glass
- Forward-facing task lighting
- Wall-glow ambient lighting on top and bottom with diffuser for a finished side view
- Suitable for damp bathroom environments
- Environmentally sustainable
- Energy efficient
- Fast lead times
- Easy installation
- Title 24 compliance available
- 10-year limited warranty
- Covered by one or more patents
- Made in America with U.S. and global components

AVAILABLE OPTIONS

- Ava™ Technology^{1,2}
- Keen™ Technology²
- Polaris™ Technology^{1,2}
- Seamless™ Technology^{1,2}
- Vive™ Technology^{1,2}
- Defogger
- CCT: 2,700K
- 0-10V dimming
- Forward-phase dimming
- 277V available³
- Custom sizes

LIGHTING SPECIFICATIONS

- Natural-looking LED light color
- CRI: 90+
- CCT: 3,000 Kelvin
- Replaceable LEDs
- 720 lumens per foot
- Maximum 100 lumens per watt efficacy
- Calculated L₇₀ 52,000-hour LED lifespan

SAFETY SPECIFICATIONS

- Entire assembly meets UL/cUL standards
- International certifications
- Safety-backed mirror

INSTALLATION SPECIFICATIONS

- 120V-240V hardwire electrical connection; provide 36" whip; junction box not required
- Chassis should be mounted to wall studs; mounting holes are provided
- Controlled by non-dimming on/off wall switch
- Installation wiring may be different on mirrors equipped with additional options
- Fixture can only be hung in the WxH orientation as shown; fixture is not field-interchangeable

¹ Minimum order quantity required.

² See technology specification sheets for more details.

³ May not be compatible with all upgrades and options.



Radiance™ Lighted Mirror

Unmatched task lighting finds a home in a new slim design to create a spectacular Radiance™. Boasting brilliant inward-facing directional lighting and a sublimely sleek look, it can serve flawlessly in virtually any room.

DIMENSIONS

- 23"W x 34.75"H (584mm x 883mm)
- 34.75"W x 34.75"H (883mm x 883mm)
- 46.75"W x 34.75"H (1,187mm x 883mm)
- 58.50"W x 34.75"H (1,486mm x 883mm)

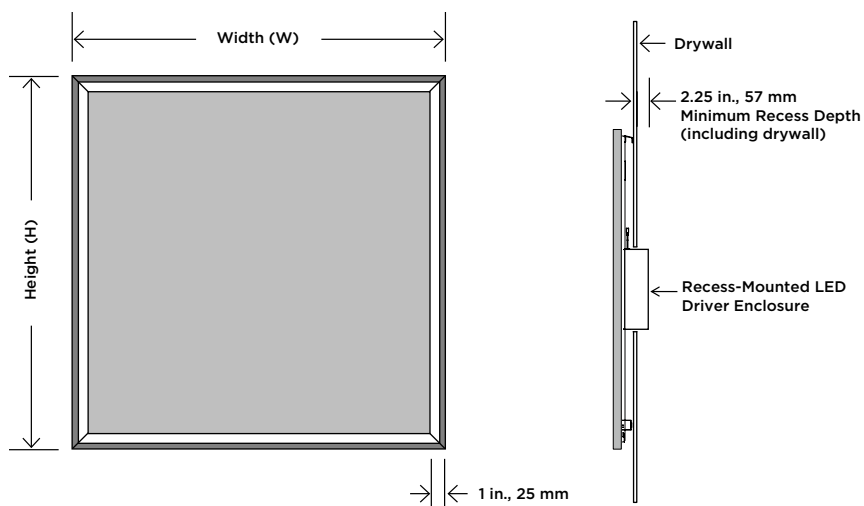

FEATURES AND BENEFITS

- Lead-free, copper-free, corrosion-resistant OmegaMirror™ glass
- Inward-facing task lighting for brilliant facial illumination
- Greater illuminance with half the power consumption of traditional LED mirrors
- Sleek and modern profile
- Suitable for damp bathroom environments
- Environmentally sustainable
- Energy efficient
- Fast lead times
- Easy installation
- Title 24 compliance available
- 10-year limited warranty
- Patent pending
- Made in America with U.S. and global components

AVAILABLE OPTIONS

- Keen™ Technology^{1,2}
- Seamless™ Technology^{1,2}
- Defogger¹
- 0-10V dimming¹
- Forward-phase dimming
- Recessed (standard) or surface mount (optional)
- Silver finish (standard); matte black finish (optional)
- Custom frames¹
- Custom sizes¹

LIGHTING SPECIFICATIONS

- Natural-looking LED light color
- Replaceable LEDs
- CRI: 90+
- CCT: 3,000 Kelvin (appears 2,700K after diffusion)
- 223 lumens per foot
- Calculated L₇₀ 140,000-hour LED lifespan
- Maximum 100 lumens per watt efficacy

SAFETY SPECIFICATIONS

- Entire assembly meets UL/CUL standards
- International certifications
- Safety-backed mirror

INSTALLATION SPECIFICATIONS

- 120V or 277V hardwire electrical connection; provide 12" whip; junction box not required
- Fixture should be mounted to wall studs; wall cleat provided
- Driver enclosure box requires recess for mounting
- Controlled by non-dimming on/off wall switch
- Installation wiring may be different on mirrors equipped with additional options
- Fixture can only be hung in the WxH orientation as shown; fixture is not field-interchangeable

¹ Minimum order quantity required.

² See technology specification sheets for more details.



Reflection™ Lighted Mirror

Two beautiful frosted bands of luminescent LED lights are surrounded by a stylishly modern frame, creating a sublime Reflection™ that adds a distinct statement of prestige to your bedroom or bathroom.

DIMENSIONS

- 29"W x 41"H
(737mm x 1041mm)
- 41"W x 41"H
(1041mm x 1041mm)
- 53"W x 41"H
(1346mm x 1041mm)
- 65"W x 41"H
(1651mm x 1041mm)

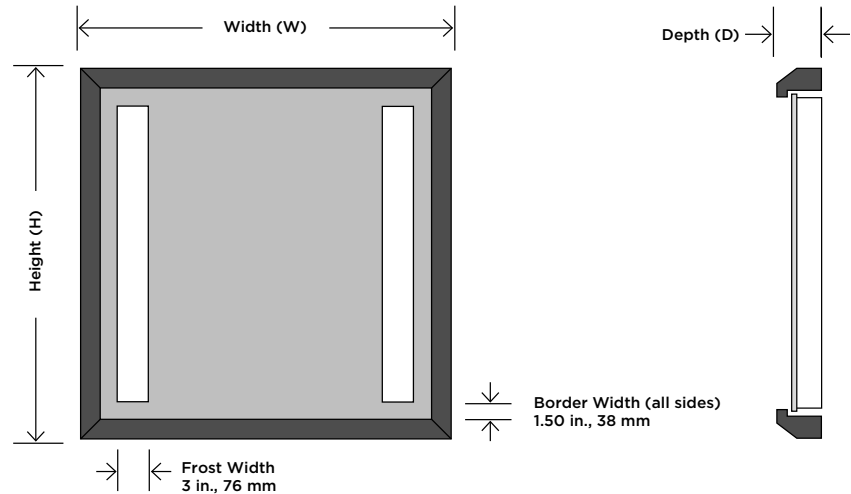

FEATURES AND BENEFITS

- Lead-free, copper-free, corrosion-resistant OmegaMirror™ glass
- Forward-facing task lighting
- Suitable for damp bathroom environments
- Environmentally sustainable
- Energy efficient
- Fast lead times
- Easy installation
- ADA compliant
- Title 24 compliance available
- 10-year limited warranty
- Covered by one or more patents
- Made in America with U.S. and global components

AVAILABLE OPTIONS

- Ava™ Technology^{1,2}
- Keen™ Technology²
- Polaris™ Technology^{1,2}
- Seamless™ Technology^{1,2}
- Vive™ Technology^{1,2}
- Defogger
- CCT: 2,700K
- 0-10V dimming
- Forward-phase dimming
- 277V available³
- Urban Profile frame ebony finish standard; other finishes available
- Custom frames¹
- Custom sizes

LIGHTING SPECIFICATIONS

- Natural-looking LED light color
- CRI: 90+
- CCT: 3,000 Kelvin
- Replaceable LEDs
- 604 lumens per foot
- Maximum 100 lumens per watt efficacy
- Calculated L₇₀ 124,000-hour LED lifespan

SAFETY SPECIFICATIONS

- Entire assembly meets UL/CUL standards
- International certifications
- Safety-backed mirror

INSTALLATION SPECIFICATIONS

- 120V-240V hardwire electrical connection; provide 36" whip; junction box not required
- Chassis should be mounted to wall studs; mounting holes are provided
- Controlled by non-dimming on/off wall switch
- Installation wiring may be different on mirrors equipped with additional options
- Fixture can only be hung in the WxH orientation as shown; fixture is not field-interchangeable

¹ Minimum order quantity required.

² See technology specification sheets for more details.

³ May not be compatible with all upgrades and options.



Serenity™ Lighted Mirror

Within an atmosphere of peaceful bliss and ethereal light, you'll find Serenity™. Loved for its perpetually elegant design and beautiful ambient wall glow, this splendid centerpiece can turn any room into a calming oasis.

DIMENSIONS

- 24"W x 36"H (610mm x 914mm)
- 30"W x 42"H (762mm x 1067mm)
- 36"W x 36"H (914mm x 914mm)
- 42"W x 42"H (1067mm x 1067mm)
- 48"W x 36"H (1219mm x 914mm)
- 54"W x 42"H (1372mm x 1067mm)
- 60"W x 36"H (1524mm x 914mm)
- 66"W x 42"H (1676mm x 1067mm)

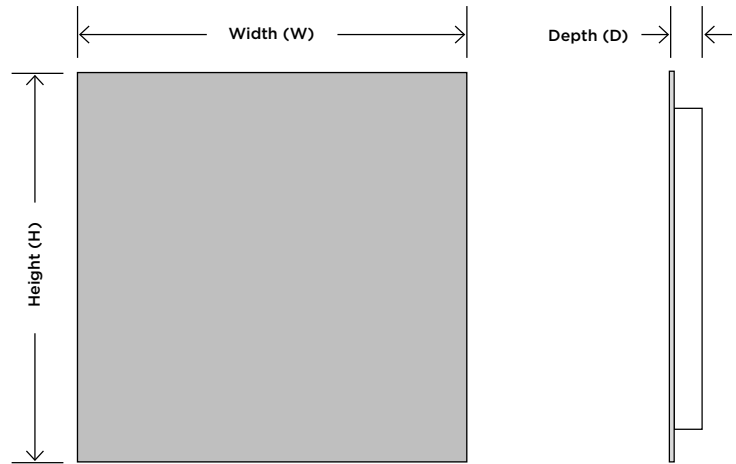

FEATURES AND BENEFITS

- Lead-free, copper-free, corrosion-resistant OmegaMirror™ glass
- Wall-glow ambient lighting on all four sides with diffuser for a finished side view
- Suitable for damp bathroom environments
- Environmentally sustainable
- Energy efficient
- Fast lead times
- Easy installation
- ADA compliant
- Title 24 compliance available
- 10-year limited warranty
- Covered by one or more patents
- Made in America with U.S. and global components

AVAILABLE OPTIONS

- Ava™ Technology^{1,2}
- Keen™ Technology²
- Polaris™ Technology^{1,2}
- Seamless™ Technology^{1,2}
- Vive™ Technology^{1,2}
- Defogger
- CCT: 2,700K
- 0-10V dimming
- Forward-phase dimming
- 277V available³
- Custom sizes

LIGHTING SPECIFICATIONS

- Natural-looking LED light color
- CRI: 90+
- CCT: 3,000 Kelvin
- Replaceable LEDs
- 720 lumens per foot
- Maximum 100 lumens per watt efficacy
- Calculated L₇₀ 52,000-hour LED lifespan

SAFETY SPECIFICATIONS

- Entire assembly meets UL/cUL standards
- International certifications
- Safety-backed mirror

INSTALLATION SPECIFICATIONS

- 120V-240V hardwire electrical connection; provide 36" whip; junction box not required
- Chassis should be mounted to wall studs; mounting holes are provided
- Controlled by non-dimming on/off wall switch
- Installation wiring may be different on mirrors equipped with additional options
- Fixture can only be hung in the WxH orientation as shown; fixture is not field-interchangeable

¹ Minimum order quantity required.

² See technology specification sheets for more details.

³ May not be compatible with all upgrades and options.



Silhouette™ Lighted Mirror

An illusion of free-floating reflection merges seamlessly with resplendent light to create the perfect Silhouette™. With practical task lighting and soft wall glow, it will illuminate your bathroom in brilliant splendor.

DIMENSIONS

- 24"W x 36"H (610mm x 914mm)
- 30"W x 42"H (762mm x 1067mm)
- 36"W x 36"H (914mm x 914mm)
- 42"W x 42"H (1067mm x 1067mm)
- 48"W x 36"H (1219mm x 914mm)
- 54"W x 42"H (1372mm x 1067mm)
- 60"W x 36"H (1524mm x 914mm)
- 66"W x 42"H (1676mm x 1067mm)

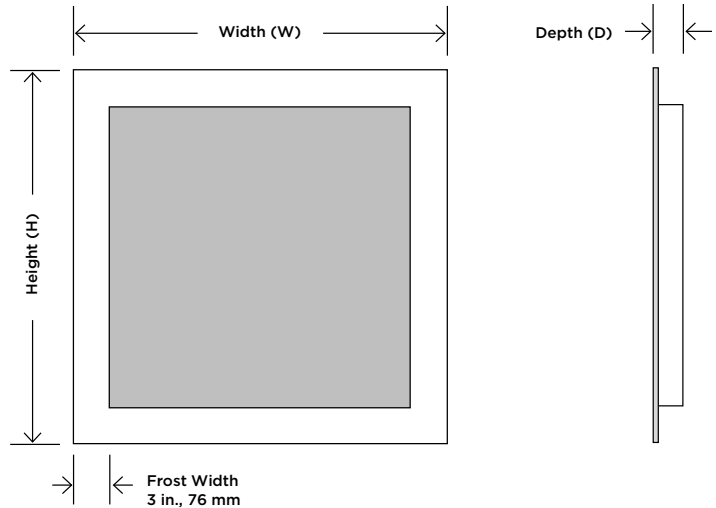

FEATURES AND BENEFITS

- Lead-free, copper-free, corrosion-resistant OmegaMirror™ glass
- Forward-facing task lighting
- Wall-glow ambient lighting on all four sides with diffuser for a finished side view
- Suitable for damp bathroom environments
- Environmentally sustainable
- Energy efficient
- Fast lead times
- Easy installation
- Title 24 compliance available
- 10-year limited warranty
- Covered by one or more patents
- Made in America with U.S. and global components

AVAILABLE OPTIONS

- Ava™ Technology^{1,2}
- Keen™ Technology²
- Polaris™ Technology^{1,2}
- Seamless™ Technology^{1,2}
- Vive™ Technology^{1,2}
- Defogger
- CCT: 2,700K
- 0-10V dimming
- Forward-phase dimming
- 277V available³
- Custom sizes

LIGHTING SPECIFICATIONS

- Natural-looking LED light color
- CRI: 90+
- CCT: 3,000 Kelvin
- Replaceable LEDs
- 720 lumens per foot
- Maximum 100 lumens per watt efficacy
- Calculated L₇₀ 52,000-hour LED lifespan

SAFETY SPECIFICATIONS

- Entire assembly meets UL/cUL standards
- International certifications
- Safety-backed mirror

INSTALLATION SPECIFICATIONS

- 120V-240V hardwire electrical connection; provide 36" whip; junction box not required
- Chassis should be mounted to wall studs; mounting holes are provided
- Controlled by non-dimming on/off wall switch
- Installation wiring may be different on mirrors equipped with additional options
- Fixture can only be hung in the WxH orientation as shown; fixture is not field-interchangeable

¹ Minimum order quantity required.

² See technology specification sheets for more details.

³ May not be compatible with all upgrades and options.



Trinity™ Lighted Mirror

A well-balanced shape, sleek lighted border, and soothing wall glow merge together in a breathtaking Trinity™ that promises to bring any space to life.

DIMENSIONS

- 21" W x 30" H (Oval) (533mm x 762mm)
- 30" diameter (762mm)
- 36" diameter (914mm)

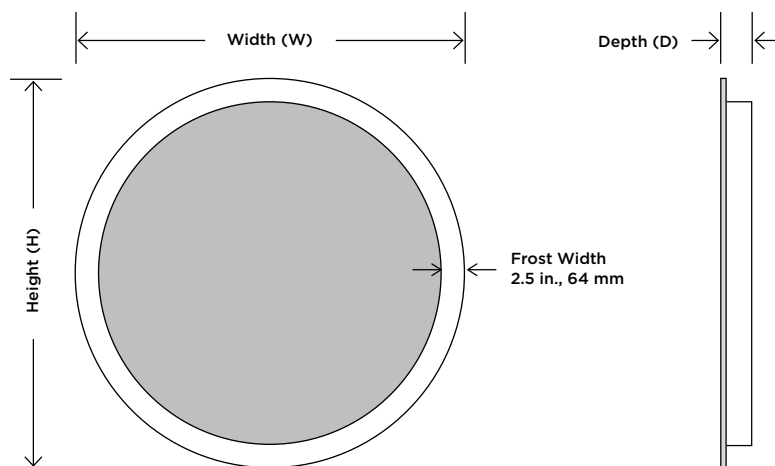

FEATURES AND BENEFITS

- Lead-free, copper-free, corrosion-resistant OmegaMirror™ glass
- Forward-facing task lighting
- Wall-glow ambient lighting
- Suitable for damp bathroom environments
- Environmentally sustainable
- Energy efficient
- Fast lead times
- Easy installation
- Title 24 compliance available
- 10-year limited warranty
- Covered by one or more patents
- Made in America with U.S. and global components

AVAILABLE OPTIONS

- Ava™ Technology^{1,2}
- Keen™ Technology²
- Polaris™ Technology^{1,2}
- Seamless™ Technology^{1,2}
- Vive™ Technology^{1,2}
- Defogger
- CCT: 2,700K
- 0-10V dimming
- Forward-phase dimming
- 277V available³
- Custom sizes

LIGHTING SPECIFICATIONS

- Natural-looking LED light color
- CRI: 90+
- CCT: 3,000 Kelvin
- Replaceable LEDs
- 720 lumens per foot
- Maximum 100 lumens per watt efficacy
- Calculated L₇₀ 52,000-hour LED lifespan

SAFETY SPECIFICATIONS

- Entire assembly meets UL/cUL standards
- International certifications
- Safety-backed mirror

INSTALLATION SPECIFICATIONS

- 120V-240V hardwire electrical connection; provide 36" whip; junction box not required
- Chassis should be mounted to wall studs; mounting holes are provided
- Controlled by non-dimming on/off wall switch
- Installation wiring may be different on mirrors equipped with additional options
- Fixture can only be hung in the WxH orientation as shown; fixture is not field-interchangeable

¹ Minimum order quantity required.

² See technology specification sheets for more details.

³ May not be compatible with all upgrades and options.





POLYCARBONATE MIRRORS



Sydney Opera House
Sydney, Australia

Accord™ Polycarbonate Mirror

The simplicity of this mirror will strike a harmonious Accord™ with all who see and use it. Fabricated from durable polycarbonate material, it's a natural choice when break-resistant function is paramount.

DIMENSIONS

- 24"W x 36"H (610mm x 914mm)
- 30"W x 42"H (762mm x 1067mm)
- 36"W x 36"H (914mm x 914mm)
- 36"W x 42"H (914mm x 1067mm)
- 48"W x 36"H (1219mm x 914mm)

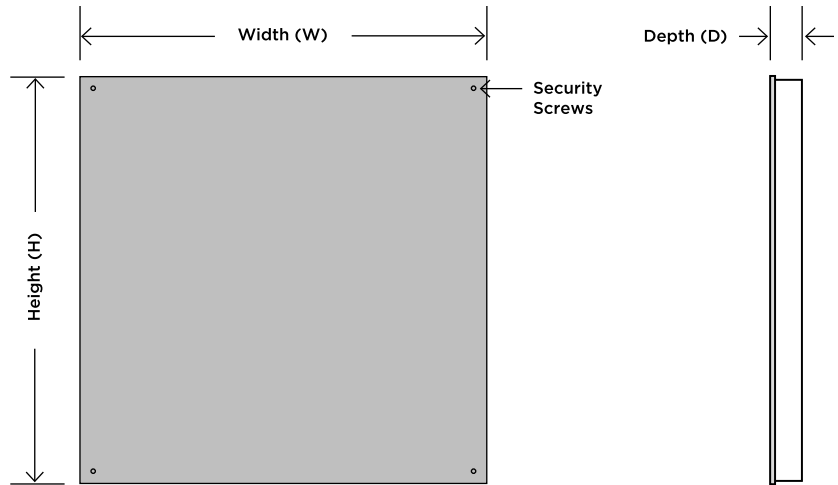

FEATURES AND BENEFITS

- Impact-resistant polycarbonate mirror
- Scratch-resistant coating
- Suitable for damp bathroom environments
- ADA compliant
- Title 24 compliance available
- 1-year limited warranty
- Made in America with U.S. and global components

AVAILABLE OPTIONS

- Custom sizes¹

SAFETY SPECIFICATIONS

- Entire assembly meets UL/cUL standards
- Ligature resistant
- Tamper-resistant security hardware

INSTALLATION SPECIFICATIONS

- Unit to be flush recess mounted into wall and be mounted to wall studs; mounting holes are provided
- Secure unit in recess using pick-proof silicone (not included)
- Fixture can only be hung in the WxH orientation as shown; fixture is not field-interchangeable

¹ Minimum order quantity required.



Placid™ Polycarbonate Mirror

The soothing, rounded shape of this elegant lighted mirror evokes a calm and Placid™ response. Featuring break-resistant polycarbonate material, this mirrored centerpiece is ideal for environments where impact-resistant mirrors are preferred.

DIMENSIONS

- 30" diameter (762mm)
- 36" diameter (914mm)
- 24"W x 36"H (610mm x 914mm)

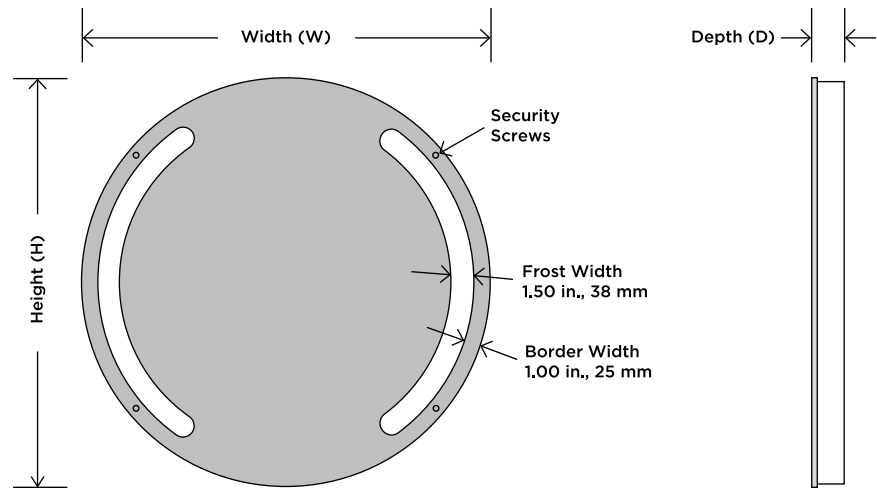

FEATURES AND BENEFITS

- Impact-resistant polycarbonate mirror
- Scratch-resistant coating
- Forward-facing task lighting
- Suitable for damp bathroom environments
- Energy efficient
- ADA compliant
- Title 24 compliance available
- 1-year limited warranty
- Made in America with U.S. and global components

AVAILABLE OPTIONS

- CCT: 3,000K
- 0-10V dimming¹
- Forward-phase dimming¹
- 277V available^{1,2}
- Custom sizes¹

LIGHTING SPECIFICATIONS

- Natural-looking LED light color
- CRI: 90+
- CCT: 2,700 Kelvin
- 604 lumens per foot
- Maximum 100 lumens per watt efficacy
- Calculated L₇₀ 124,000-hour LED lifespan

SAFETY SPECIFICATIONS

- Entire assembly meets UL/cUL standards
- Ligature resistant
- Tamper-resistant security hardware

INSTALLATION SPECIFICATIONS

- 120V-240V hardwire electrical connection; provide 36" whip; junction box not required
- Unit to be flush recess mounted in wall and be mounted to wall studs; mounting holes are provided
- Secure unit in recess using pick-proof silicone (not included)
- Controlled by non-dimming on/off wall switch
- Installation wiring may be different on mirrors equipped with additional options
- Fixture can only be hung in the WxH orientation as shown; fixture is not field-interchangeable

¹ Minimum order quantity required.

² May not be compatible with all upgrades and options.

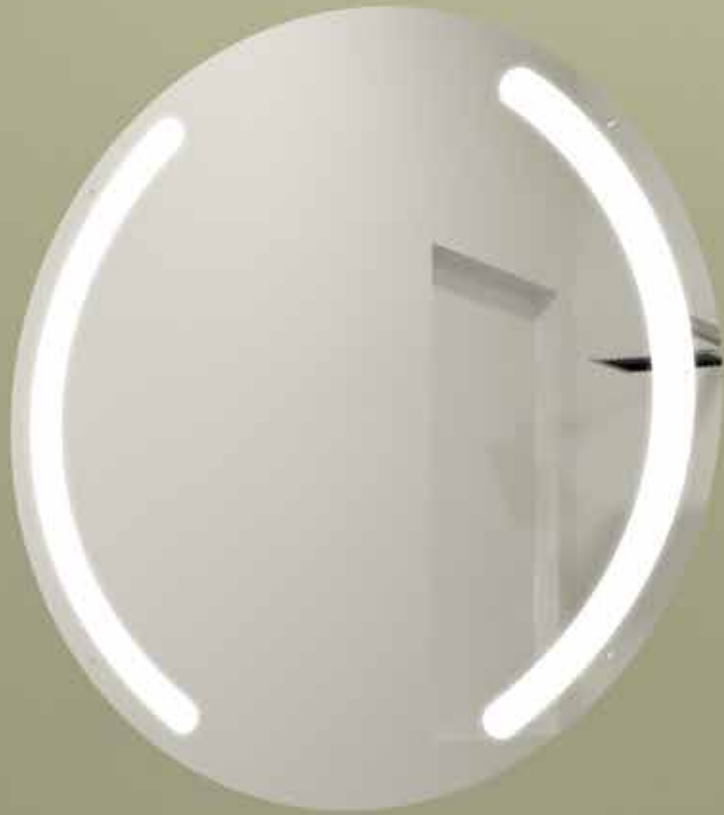

Selah™ Polycarbonate Mirror

The gentle, serene lines of the Selah™ invite you to take a peaceful pause. Constructed of impact-resistant polycarbonate material, this lighted mirror is well-suited for spaces where break-resistive performance is essential.

DIMENSIONS

- 24"W x 36"H (610mm x 914mm)
- 30"W x 42"H x 2"D (762mm x 1067mm)
- 36"W x 36"H (914mm x 914mm)
- 36"W x 42"H (914mm x 1067mm)
- 48"W x 36"H (1219mm x 914mm)

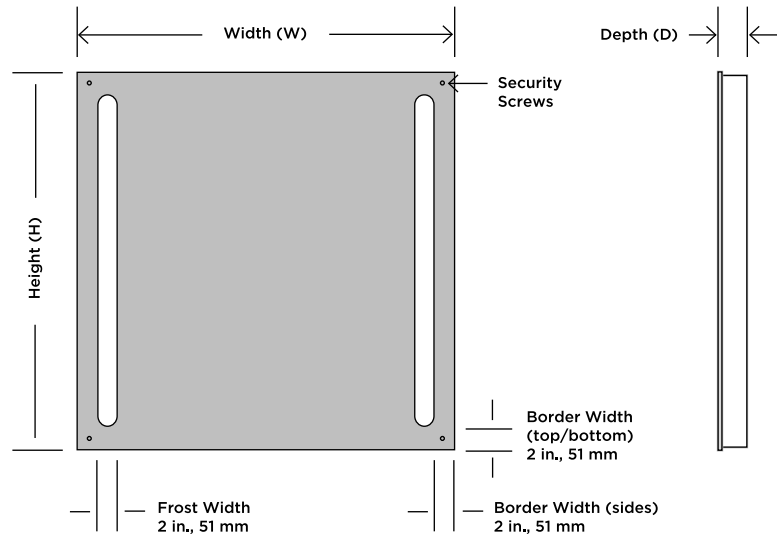

FEATURES AND BENEFITS

- Impact-resistant polycarbonate mirror
- Scratch-resistant coating
- Forward-facing task lighting
- Suitable for damp bathroom environments
- Energy efficient
- ADA compliant
- Title 24 compliance available
- 1-year limited warranty
- Made in America with U.S. and global components

AVAILABLE OPTIONS

- CCT: 3,000K
- 0-10V dimming¹
- Forward-phase dimming¹
- 277V available^{1,2}
- Custom sizes¹

LIGHTING SPECIFICATIONS

- Natural-looking LED light color
- CRI: 90+
- CCT: 2,700 Kelvin
- 604 lumens per foot
- Maximum 100 lumens per watt efficacy
- Calculated L_{70} 124,000-hour LED lifespan

SAFETY SPECIFICATIONS

- Entire assembly meets UL/cUL standards
- Ligature resistant
- Tamper-resistant security hardware

INSTALLATION SPECIFICATIONS

- 120V-240V hardwire electrical connection; provide 36" whip; junction box not required
- Unit to be flush recess mounted into wall and be mounted to wall studs; mounting holes are provided
- Secure unit in recess using pick-proof silicone (not included)
- Controlled by non-dimming on/off wall switch
- Installation wiring may be different on mirrors equipped with additional options
- Fixture can only be hung in the WxH orientation as shown; fixture is not field-interchangeable

¹ Minimum order quantity required.

² May not be compatible with all upgrades and options.





MIRROR TVS



Golden Gate Bridge
San Francisco, California

Fusion™ Lighted Mirror TV

This high-tech, high-style Fusion™ is defined by clean lines, efficient natural-looking LED lighting, and an ultra-sharp LED HD display — ideal for adding a definitive statement of prestige to any bathroom.

DIMENSIONS

- 36"W x 36" (914mm x 914mm)
- 48"W x 36"H (1219mm x 914mm)
- 60"W x 36"H (1524mm x 914mm)

Fixture must be mounted in the width x height orientation listed.

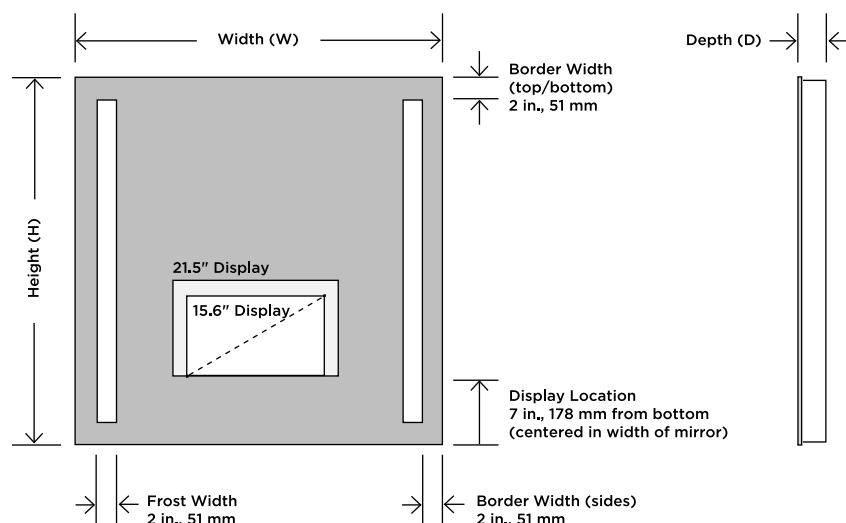

FEATURES AND BENEFITS

- Lead-free, copper-free, corrosion-resistant OmegaMirror™ with Spectrum™ mirror glass technology
- Forward-facing task lighting
- Integrated speakers
- Suitable for damp bathroom environments
- Environmentally sustainable
- Energy efficient
- Fast lead times
- Easy installation
- 5-year limited warranty
- Covered by one or more patents
- Assembled in the USA

DISPLAY FEATURES AND BENEFITS

- 15.6" or 21.5" LED HD display¹
- 1920x1080, 16:9 widescreen ratio
- 50,000-hour panel
- Removable power supply
- Left/right out and line level audio out

- HDMI, HDMI (CEC), RS232, IR and USB connections²
- 8 watt/channel amplification with integrated state-of-the-art mini speakers for high quality stereo sound
- Waterproof remote control

AVAILABLE OPTIONS

- Ava™ Technology^{1,3}
- Keen™ Technology^{1,3}
- Polaris™ Technology^{1,3}
- Seamless™ Technology^{1,3}
- Defogger³
- Iris® glass³
- CCT: 2,700K³
- 0-10V dimming³
- Forward-phase dimming³
- 277V available^{3,4}
- Custom sizes³

AVAILABLE AUDIO OPTIONS

- Bose™ ceiling-mount speakers - flush white

SAFETY SPECIFICATIONS

- Entire assembly meets UL/cUL standards
- International certifications
- Safety-backed mirror
- FCC compliant

LIGHTING SPECIFICATIONS

- Natural-looking LED light color
- CRI: 90+
- CCT: 3,000 Kelvin
- Replaceable LEDs
- 604 lumens per foot
- Maximum 100 lumens per watt efficacy
- Calculated L₇₀ 124,000-hour LED lifespan

INSTALLATION SPECIFICATIONS

- For installation specifications, please see Fusion Lighed mirror.

¹ See technology specification sheets for more details.

² Does not contain a tuner - external media device (STB, Cable, Etc.) required.

³ Minimum order quantity required.

⁴ May not be compatible with all upgrades and options.



Integrity™ Lighted Mirror TV

Place Integrity™ over your bathroom vanity and instantly renew your space with brilliance and motion. It features a smooth polished edge, luminous inner frame of natural-looking LED lighting, and a vibrant LED HD display.

DIMENSIONS

- 36"W x 42"H (914mm x 1067mm)
- 42"W x 42"H (1067mm x 1067mm)
- 48"W x 42"H (1219mm x 1067mm)
- 54"W x 42"H (1372mm x 1067mm)
- 60"W x 42"H (1524mm x 1067mm)
- 66"W x 42"H (1676mm x 1067mm)

Fixture must be mounted in the width x height orientation listed.

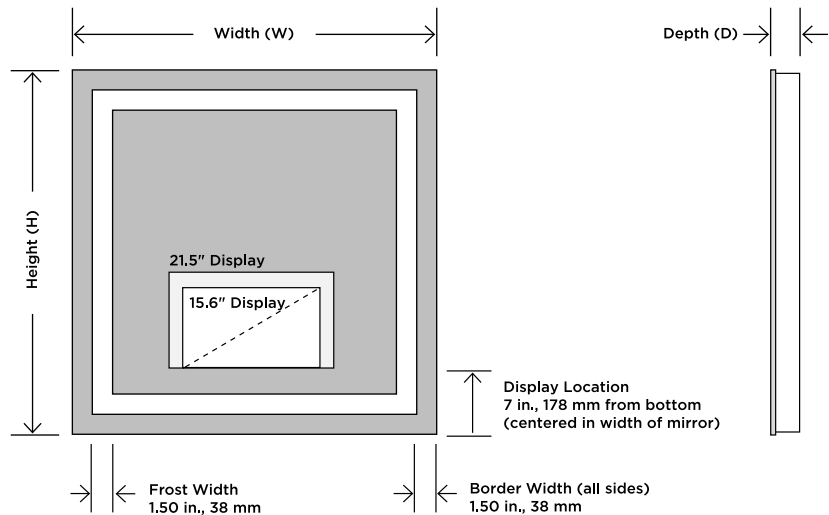

FEATURES AND BENEFITS

- Lead-free, copper-free, corrosion-resistant OmegaMirror™ with Spectrum™ mirror glass technology
- Forward-facing task lighting
- Integrated speakers
- Suitable for damp bathroom environments
- Environmentally sustainable
- Energy efficient
- Fast lead times
- Easy installation
- 5-year limited warranty
- Covered by one or more patents
- Assembled in the USA

DISPLAY FEATURES AND BENEFITS

- 15.6" or 21.5" LED HD display¹
- 1920x1080, 16:9 widescreen ratio
- 50,000-hour panel
- Removable power supply
- Left/right out and line level audio out

- HDMI, HDMI (CEC), RS232, IR and USB connections²
- 8 watt/channel amplification with integrated state-of-the-art mini speakers for high quality stereo sound
- Waterproof remote control

AVAILABLE OPTIONS

- Ava™ Technology^{1,3}
- Keen™ Technology^{1,3}
- Polaris™ Technology^{1,3}
- Seamless™ Technology^{1,3}
- Defogger³
- Iris® glass³
- CCT: 2,700K³
- 0-10V dimming³
- Forward-phase dimming³
- 277V available^{3,4}
- Custom sizes³

AVAILABLE AUDIO OPTIONS

- Bose™ ceiling-mount speakers - flush white

SAFETY SPECIFICATIONS

- Entire assembly meets UL/cUL standards
- International certifications
- Safety-backed mirror
- FCC compliant

LIGHTING SPECIFICATIONS

- Natural-looking LED light color
- CRI: 90+
- CCT: 3,000 Kelvin
- Replaceable LEDs
- 604 lumens per foot
- Maximum 100 lumens per watt efficacy
- Calculated L₇₀ 124,000-hour LED lifespan

INSTALLATION SPECIFICATIONS

- For installation specifications, please see Integrity Lighed mirror.

¹ See technology specification sheets for more details.

² Does not contain a tuner - external media device (STB, Cable, Etc.) required.

³ Minimum order quantity required.

⁴ May not be compatible with all upgrades and options.



Loft™ Mirror TV

With the Loft™ Mirror TV, the focus is on you, and the beautiful LED HD display looking back at you. Offering integrated speakers and a choice of display sizes, there's nothing standing between you and your favorite TV programming.

DIMENSIONS

- 30"W x 40"H (762mm x 1016mm)
- 40"W x 40"H (1016mm x 1016mm)
- 50"W x 40"H (1270mm x 1016mm)
- 60"W x 40"H (1524mm x 1016mm)

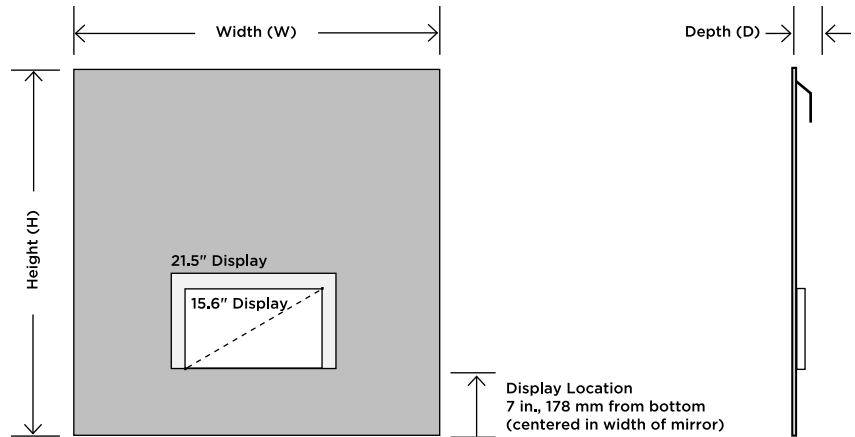

FEATURES AND BENEFITS

- Lead-free, copper-free, corrosion-resistant OmegaMirror™ with Spectrum™ mirror glass technology
- Integrated speakers
- Suitable for damp bathroom environments
- Environmentally sustainable
- Energy efficient
- Fast lead times
- Easy installation
- 5-year limited warranty
- Covered by one or more patents
- Assembled in the USA

DISPLAY FEATURES AND BENEFITS

- .6" or 21.5" LED HD display¹
- 1920x1080, 16:9 widescreen ratio
- 50,000-hour panel
- Removable power supply
- Left/right out and line level audio out

- HDMI, HDMI (CEC), RS232, IR and USB connections²
- 8 watt/channel amplification with integrated state-of-the-art mini speakers for high quality stereo sound
- Waterproof remote control

AVAILABLE OPTIONS

- Polaris™ Technology^{1,3}
- Seamless™ Technology^{1,3}
- Defogger³
- Iris® glass³
- Custom sizes³

AVAILABLE AUDIO OPTIONS

- Bose™ ceiling-mount speakers - flush white

SAFETY SPECIFICATIONS

- Entire assembly meets UL/cUL standards
- International certifications
- Safety-backed mirror
- FCC compliant

INSTALLATION SPECIFICATIONS

- Chassis should be mounted to wall studs; mounting holes are provided
- Plug display into unswitched 120-240V recessed electrical outlet and make video/audio connections behind mirror
- Fixture can only be hung in the WxH orientation as shown; fixture is not field-interchangeable

¹ See technology specification sheets for more details.

² Does not contain a tuner - external media device (STB, Cable, Etc.) required.

³ Minimum order quantity required.



Silhouette™ Lighted Mirror TV

Change your expectations of what a luxury bathroom should be by adding an awe-inspiring Silhouette™. With its vivid task lighting, soft wall glow, and a stunning LED HD display, there's no shortage of ways to leave a lasting impression.

DIMENSIONS

- 36"W x 42"H (914mm x 1067mm)
- 42"W x 42"H (1067mm x 1067mm)
- 48"W x 42"H (1219mm x 1067mm)
- 54"W x 42"H (1372mm x 1067mm)
- 60"W x 42"H (1524mm x 1067mm)
- 66"W x 42"H (1676mm x 1067mm)

Fixture must be mounted in the width x height orientation listed.

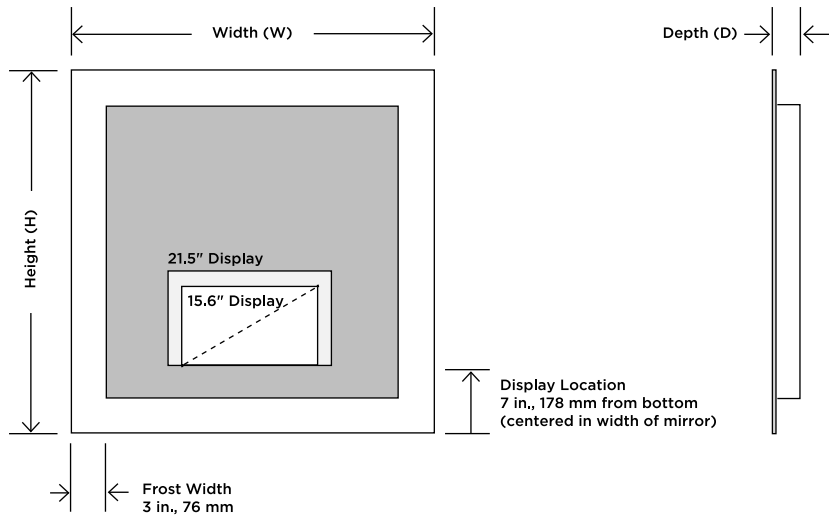

FEATURES AND BENEFITS

- Lead-free, copper-free, corrosion-resistant OmegaMirror™ with Spectrum™ mirror glass technology
- Forward-facing task lighting
- Integrated speakers
- Suitable for damp bathroom environments
- Environmentally sustainable
- Energy efficient
- Fast lead times
- Easy installation
- 5-year limited warranty
- Covered by one or more patents
- Assembled in the USA

DISPLAY FEATURES AND BENEFITS

- 15.6" or 21.5" LED HD display¹
- 1920x1080, 16:9 widescreen ratio
- 50,000-hour panel
- Removable power supply
- Left/right out and line level audio out

- HDMI, HDMI (CEC), RS232, IR and USB connections²
- 8 watt/channel amplification with integrated state-of-the-art mini speakers for high quality stereo sound
- Waterproof remote control

AVAILABLE OPTIONS

- Ava™ Technology^{1,3}
- Keen™ Technology^{1,3}
- Polaris™ Technology^{1,3}
- Seamless™ Technology^{1,3}
- Defogger³
- Iris® glass³
- CCT: 2,700K³
- 0-10V dimming³
- Forward-phase dimming³
- 277V available^{3,4}
- Custom sizes³

AVAILABLE AUDIO OPTIONS

- Bose™ ceiling-mount speakers - flush white

SAFETY SPECIFICATIONS

- Entire assembly meets UL/cUL standards
- International certifications
- Safety-backed mirror
- FCC compliant

LIGHTING SPECIFICATIONS

- Natural-looking LED light color
- CRI: 90+
- CCT: 3,000 Kelvin
- Replaceable LEDs
- 604 lumens per foot
- Maximum 100 lumens per watt efficacy
- Calculated L₇₀ 124,000-hour LED lifespan

INSTALLATION SPECIFICATIONS

- For installation specifications, please see Silhouette Lighed mirror.

¹ See technology specification sheets for more details.

² Does not contain a tuner - external media device (STB, Cable, Etc.) required.

³ Minimum order quantity required.

⁴ May not be compatible with all upgrades and options.



Stanford™ Mirror TV

Enhance your bathroom space by adding the timeless beauty and high-tech performance of the Stanford™. With a contemporary look and impressive LED HD display, it provides a plethora of entertainment, news, and sports, while doubling as a dynamic centerpiece.

DIMENSIONS

- 35"W x 45"H (889mm x 1143mm)
- 45"W x 45"H (1143mm x 1143mm)
- 55"W x 45"H (1397mm x 1143mm)
- 65"W x 45"H (1651mm x 1143mm)

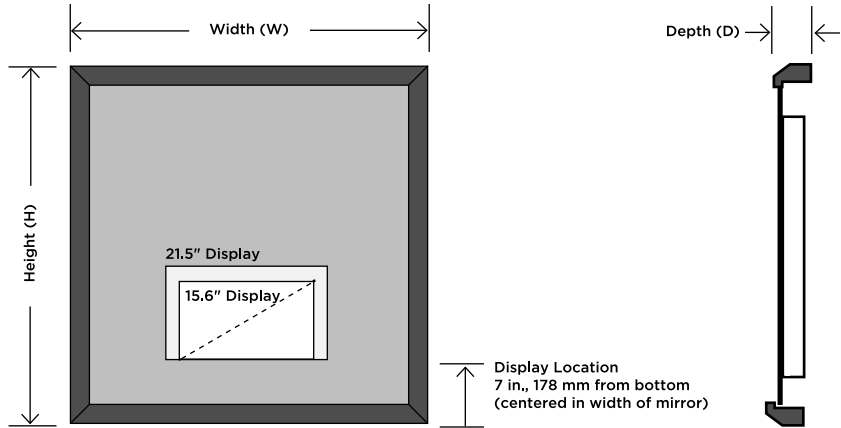

FEATURES AND BENEFITS

- Lead-free, copper-free, corrosion-resistant OmegaMirror™ with Spectrum™ mirror glass technology
- Integrated speakers
- Suitable for damp bathroom environments
- Environmentally sustainable
- Energy efficient
- Fast lead times
- Easy installation
- 5-year limited warranty
- Covered by one or more patents
- Assembled in the USA

DISPLAY FEATURES AND BENEFITS

- 15.6" or 21.5" LED HD display¹
- 1920x1080, 16:9 widescreen ratio
- 50,000-hour panel
- Removable power supply
- Left/right out and line level audio out

- HDMI, HDMI (CEC), RS232, IR and USB connections²
- 8 watt/channel amplification with integrated state-of-the-art mini speakers for high quality stereo sound
- Waterproof remote control

AVAILABLE OPTIONS

- Polaris™ Technology^{1,3}
- Seamless™ Technology^{1,3}
- Defogger³
- Iris® glass³
- Iris® glass³
- Urban Profile frame ebony finish standard; other finishes available³
- Custom frames³
- Custom sizes³

AVAILABLE AUDIO OPTIONS

- Bose™ ceiling-mount speakers - flush white

SAFETY SPECIFICATIONS

- Entire assembly meets UL/cUL standards
- International certifications
- Safety-backed mirror
- FCC compliant

INSTALLATION SPECIFICATIONS

- Chassis should be mounted to wall studs; mounting holes are provided
- Plug display into unswitched 120-240V recessed electrical outlet and make video/audio connections behind mirror
- Fixture can only be hung in the WxH orientation as shown; fixture is not field-interchangeable

¹ See technology specification sheets for more details.

² Does not contain a tuner - external media device (STB, Cable, Etc.) required.

³ Minimum order quantity required.



Loft™ Entertainment Mirror TV

Upgrade your guestroom by adding an excitement-filled Loft™. With a contemporary look and impressive HDTV, it seamlessly integrates large screen TVs into your guestroom, hiding the TV behind a reflective mirror when the TV is off.

DIMENSIONS

- 46"W x 31"H
For up to 40" TV
- 53"W x 35"H
For up to 50" TV
- 68"W x 43"H
For up to 60" TV

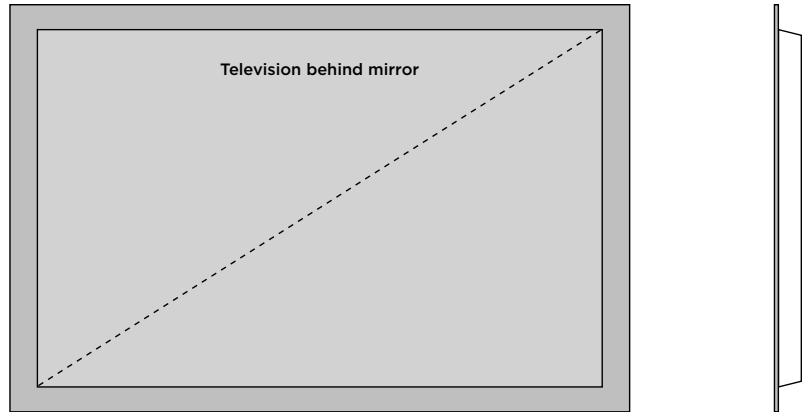

FEATURES AND BENEFITS

- Glare-resistant Iris® mirror glass
- Integrated speakers
- Environmentally sustainable
- Energy efficient
- Fast lead times
- Easy installation
- 3-year limited warranty
- Covered by one or more patents
- Assembled in the USA

TV FEATURES AND BENEFITS

- Features vary by TV selected¹

AVAILABLE OPTIONS

- Custom sizes

SAFETY SPECIFICATIONS

- Entire assembly meets UL/cUL standards
- International certifications
- Safety-backed mirror
- FCC compliant

INSTALLATION SPECIFICATIONS

- Chassis should be mounted to wall studs; mounting holes are provided
- Plug display into unswitched 120-240V recessed electrical outlet and make video/audio connections behind mirror
- Fixture can only be hung in the WxH orientation as shown; fixture is not field-interchangeable

¹ Due to the changing nature of TVs, please see sales aid for sizing and technical information.



Stanford™ Entertainment Mirror TV

The Stanford™ Entertainment Mirror TV subtly combines beautiful wood frames with mirror TV technology. The multiple framing options ensure design flexibility providing a complete solution.

DIMENSIONS

- 46"W x 31"H
For up to 40" TV
- 53"W x 35"H
For up to 50" TV
- 68"W x 43"H
For up to 60" TV

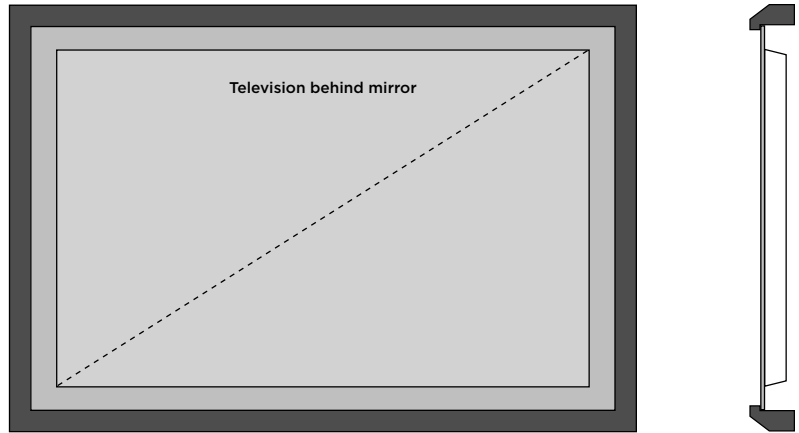

FEATURES AND BENEFITS

- Glare-resistant Iris® mirror glass
- Integrated speakers
- Environmentally sustainable
- Energy efficient
- Fast lead times
- Easy installation
- 3-year limited warranty
- Covered by one or more patents
- Assembled in the USA

TV FEATURES AND BENEFITS

- Features vary by TV selected¹

AVAILABLE OPTIONS

- Urban Profile frame ebony finish standard; other finishes available
- Custom frames²
- Custom sizes

SAFETY SPECIFICATIONS

- Entire assembly meets UL/cUL standards
- International certifications
- Safety-backed mirror
- FCC compliant

INSTALLATION SPECIFICATIONS

- Chassis should be mounted to wall studs; mounting holes are provided
- Plug display into unswitched 120-240V recessed electrical outlet and make video/audio connections behind mirror
- Fixture can only be hung in the WxH orientation as shown; fixture is not field-interchangeable

¹ Due to the changing nature of TVs, please see sales aid for sizing and technical information.

² Minimum order quantity required.





TV COVERS





The Vegas Strip
Las Vegas, Nevada

Eclipse™ TV Cover

Transform the look of your existing flat-screen TV with an Eclipse™ and turn it into a sleek, modern mirror that reflects the beauty and luxury of your living space. Our innovative Iris® glass technology provides a crisp, clear image when the TV is on, and makes it vanish when turned off — perfect for living rooms and bedrooms.

DIMENSIONS

- 43.5"W x 27.5"H (1105mm x 699mm)
Fits a 40"-43" television
- 54"W x 33.25"H (1372mm x 845mm)
Fits a 48"-55" television
- 62.75"W x 38.25"H (1594mm x 972mm)
Fits a 58"-65" television
- 71.25"W x 43.25"H (1810mm x 1099mm)
Fits a 75" television

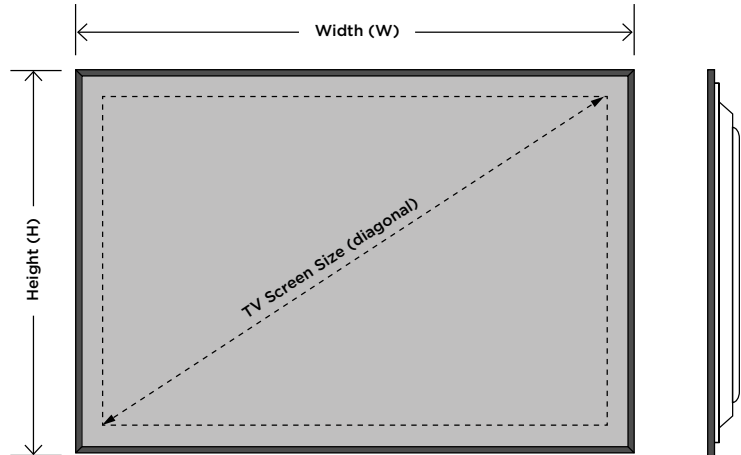

FEATURES AND BENEFITS

- Glare-resistant Iris® mirror glass
- Fast lead times
- Quick and easy to install over existing flat-screen TVs
- Universal design fits virtually all flat-screen TVs
- 3-year limited warranty
- Covered by one or more patents
- Made in America with U.S. and global components

TV FEATURES AND BENEFITS

- Easy-fit TV mounting solution¹

AVAILABLE OPTIONS

- Gloss black finish standard
- Custom frames²
- Custom sizes²

INSTALLATION SPECIFICATIONS

- Eclipse is designed to mount over flat-screen TVs built from 2013 to present
- Eclipse is not compatible with curved or tabletop TVs
- Existing flat-screen TV must be installed on a VESA wall mount (VESA mount not included)
- Eclipse is attached to existing VESA wall mount using included hardware
- Fixture can only be hung in the WxH orientation as shown; fixture is not field-interchangeable

¹ TV not included.

² Minimum order quantity required.



A camel with a colorful, patterned saddle is sitting on the ground in front of a stone wall. The Great Pyramid of Giza is visible in the background under a clear sky. The camel is facing right and has a brown halter. The saddle is decorated with red, blue, and white geometric patterns and tassels. The stone wall is made of large, rectangular blocks. The ground is sandy and dusty.

MIRRORED CABINETS



Pyramids of Giza
Cairo, Egypt

Ambiance™ Mirrored Cabinet

Add Ambiance™ to your bathroom space and create a uniquely modern look with real-world functionality. It features a frame of lustrous light and a precision polished edge — an ideal match for your contemporary décor.

DIMENSIONS

- 23.25"W x 30.00"H (590mm x 762mm)
- 23.25"W x 40.00"H (590mm x 1016mm)

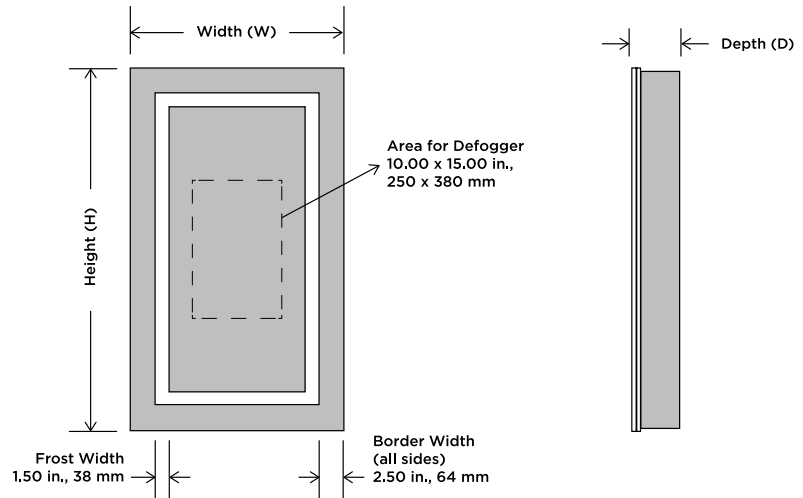

FEATURES AND BENEFITS

- Copper-free, corrosion-resistant mirror glass
- Forward-facing task lighting in the mirror door
- 0-10V dimming
- Matte silver aluminum cabinet body
- Mirrored interior with top light
- Integrated nightlight in cabinet door
- Integrated defogger
- Adjustable glass shelves
- Surface mounting kit included
- Two electrical outlets and two USB ports
- Suitable for damp bathroom environments
- Environmentally sustainable
- Energy efficient
- Easy installation
- Title 24 compliance available
- 3-year limited warranty
- Covered by one or more patents
- Designed in the USA

AVAILABLE OPTIONS

- Ganging Kit for installation of side-by-side mirrored cabinets
- Right or left door swing

LIGHTING SPECIFICATIONS

- Natural-looking LED light color
- CRI: 90+
- CCT: 3,000 Kelvin
- Replaceable LEDs
- 516 lumens per foot
- Maximum 100 lumens per watt efficacy
- Calculated L₇₀ 36,000-hour LED lifespan

SAFETY SPECIFICATIONS

- Entire assembly meets UL/cUL standards
- Defogger serves as safety backing

INSTALLATION SPECIFICATIONS

- 120V hardwire electrical connection; provide 2x12" whips; junction box not required; interior outlet should be on 120V, unswitched circuit; refer to installation instructions for further details and options
- Cabinet can be recess-mounted to wall studs; mounting holes are provided
- Controlled by 0-10V dimming wall switch
- Defogger and Internal light controlled by internal mechanical button
- Rough-in dimensions for recessed mounted cabinets can be obtained from either the fixture sales aid or by measuring the cabinet back
- Fixture can only be hung in the WxH orientation as shown; fixture is not field-interchangeable



Ascension™ Mirrored Cabinet

Combining a streamlined design and ascending vertical lighting pattern with touch dimming technology, the Ascension™ Mirrored Cabinet brings incredible versatility and style to any bathroom.

DIMENSIONS

- 23.25"W x 30.00"H (590mm x 864mm)
- 23.25"W x 36.00"H (590mm x 914mm)
- 23.25"W x 40.00"H (590mm x 1016mm)

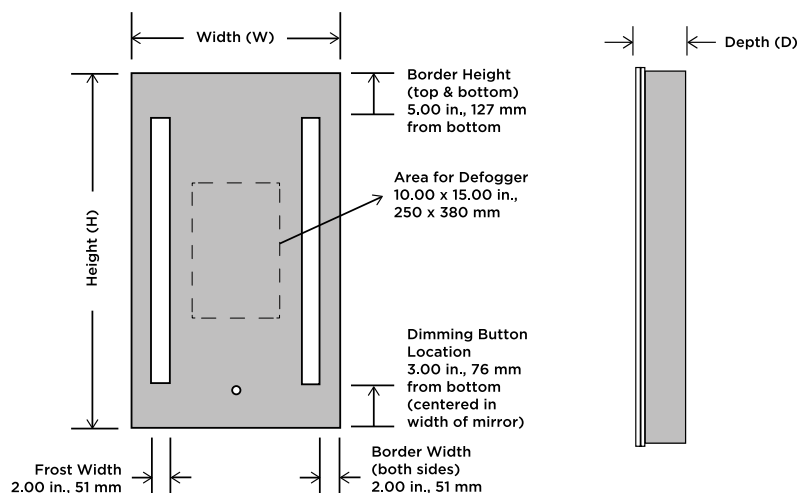

FEATURES AND BENEFITS

- Copper-free, corrosion-resistant mirror glass
- Forward-facing task lighting in the mirror door
- 0-10V dimming
- Matte silver aluminum cabinet body
- Mirrored interior with top light
- Integrated nightlight in cabinet door
- Integrated defogger
- Adjustable glass shelves
- Surface mounting kit included
- Two electrical outlets and two USB ports
- Suitable for damp bathroom environments
- Environmentally sustainable
- Energy efficient
- Easy installation
- ADA compliant
- Title 24 compliance available
- 3-year limited warranty
- Covered by one or more patents
- Designed in the USA

AVAILABLE OPTIONS

- Ganging Kit for installation of side-by-side mirrored cabinets
- Right or left door swing

LIGHTING SPECIFICATIONS

- Natural-looking LED light color
- CRI: 90+
- CCT: 3,000 Kelvin
- Replaceable LEDs
- 516 lumens per foot
- Maximum 100 lumens per watt efficacy
- Calculated L_{70} 36,000-hour LED lifespan

SAFETY SPECIFICATIONS

- Entire assembly meets UL/cUL standards
- Defogger serves as safety backing

INSTALLATION SPECIFICATIONS

- 120V hardwire electrical connection; provide 2x12" whips; junction box not required; interior outlet should be on 120V, unswitched circuit; refer to installation instructions for further details and options
- Cabinet can be recess-mounted to wall studs; mounting holes are provided
- Controlled by capacitive touch button on fixture or non-dimming on/off switch
- Defogger and Internal light controlled by internal mechanical button
- Rough-in dimensions for recessed mounted cabinets can be obtained from either the fixture sales aid or by measuring the cabinet back
- Fixture can only be hung in the WxH orientation as shown; fixture is not field-interchangeable



Simplicity™ Mirrored Cabinet

Simplicity™ in both form and function can easily accentuate any design style you choose. It features exceptional reflectivity, glass shelving, and conveniently placed integrated outlets.

DIMENSIONS

- 23.25"W x 40.00"H (590mm x 1016mm)

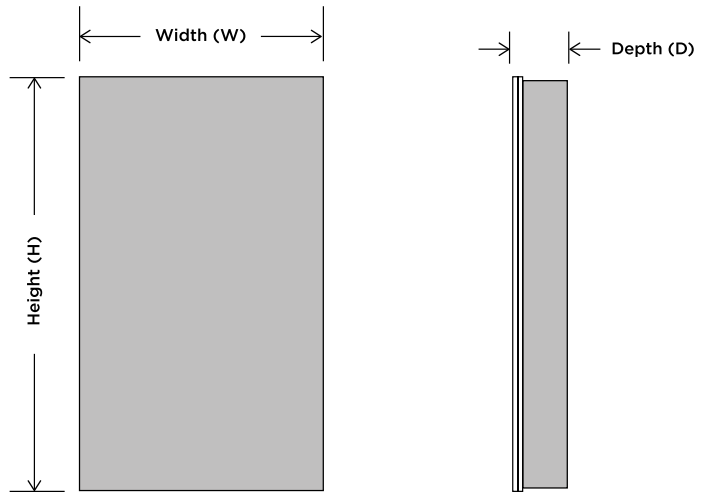

FEATURES AND BENEFITS

- Copper-free, corrosion-resistant mirror glass
- Matte silver aluminum cabinet body
- Mirrored interior with top light
- Adjustable glass shelves
- Surface mounting kit included
- Two electrical outlets and two USB ports
- Suitable for damp bathroom environments
- Environmentally sustainable
- Energy efficient
- Easy installation
- ADA compliant
- Title 24 compliance available
- 3-year limited warranty
- Covered by one or more patents
- Designed in the USA

AVAILABLE OPTIONS

- Ganging Kit for installation of side-by-side mirrored cabinets
- Right or left door swing

SAFETY SPECIFICATIONS

- Entire assembly meets UL/cUL standards

INSTALLATION SPECIFICATIONS

- 120V hardwire electrical connection; provide 2x12" whips; junction box not required; interior outlet should be on 120V, unswitched circuit; refer to installation instructions for further details and options
- Cabinet can be recess-mounted to wall studs; mounting holes are provided
- Internal light controlled by internal mechanical button
- Rough-in dimensions for recessed mounted cabinets can be obtained from either the fixture sales aid or by measuring the cabinet back
- Fixture can only be hung in the WxH orientation as shown; fixture is not field-interchangeable





MAKEUP MIRRORS





Cliffs of Moher
County Clare, Ireland

Blush™ Makeup Mirror

Looking your best is easy with a Blush™. It features a halo of natural-looking LED light, up-and-down tilt, and 5X magnification — great for makeup application.

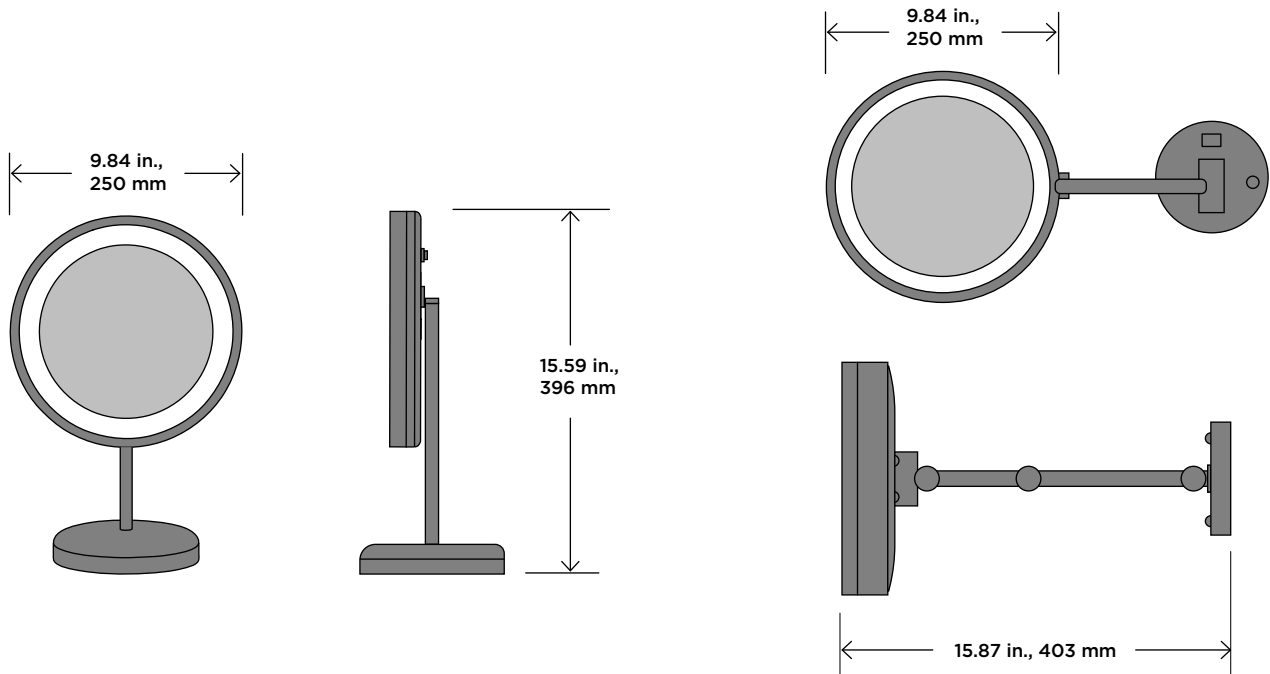

FEATURES AND BENEFITS

- Corrosion-resistant mirror glass
- Forward-facing task lighting
- Up-and-down tilt
- Side-to-side swivel (wall mount only)
- 5X magnification
- Suitable for damp bathroom environments
- Energy efficient
- Easy installation
- 1-year limited warranty
- Designed in America and sourced globally

AVAILABLE OPTIONS

- Polished stainless finish standard, brushed stainless and matte black finishes available^{1,2}
- Hardwired wall mount standard; electrical cord countertop available

LIGHTING SPECIFICATIONS

- Natural-looking LED light color
- CCT: 3,000 Kelvin

SAFETY SPECIFICATIONS

- Entire assembly meets UL/cUL standards

INSTALLATION SPECIFICATIONS

- 120V or 240V electrical connection
- Wall mount model comes ready for hardwire and requires a standard 3.5" or 4" octagonal electrical box
- Countertop model comes with a plug that must be plugged into an outlet
- Controlled by on/off switch on fixture
- Fixture can only be hung in the WxH orientation as shown; fixture is not field-interchangeable

¹ Minimum order quantity required.

² May not be available for all configurations.



Charm™ Makeup Mirror

This sleek, contemporary makeup mirror will Charm™ you with a pronounced ring of light, dual 1X/5X magnification, and an articulated arm for near and far viewing.

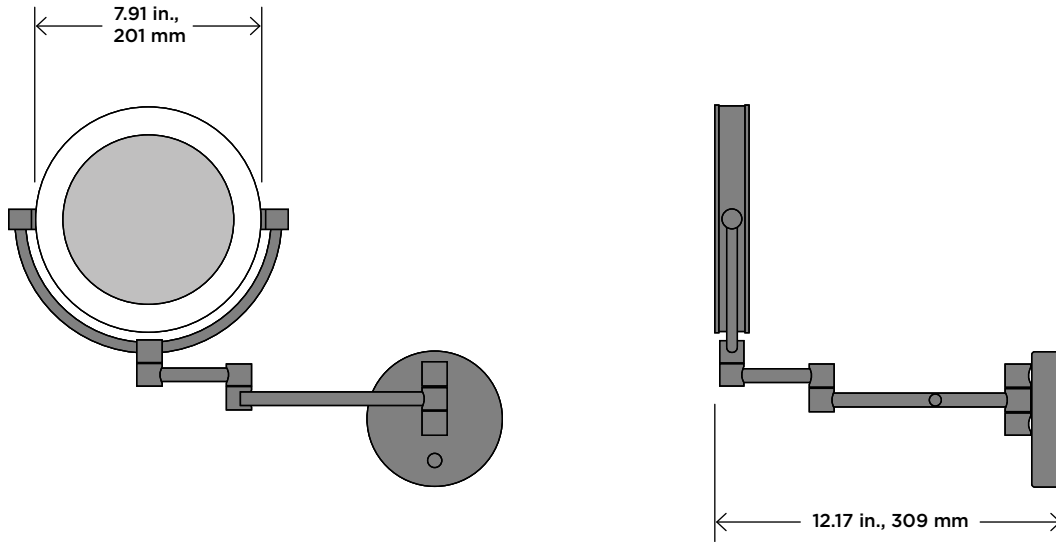

FEATURES AND BENEFITS

- Corrosion-resistant mirror glass
- Forward-facing task lighting
- Up-and-down tilt
- Side-to-side swivel with full pivot
- 5X and 1X magnification
- Hardwired wall mount
- Suitable for damp bathroom environments
- Energy efficient
- Easy installation
- 1-year limited warranty
- Designed in America and sourced globally

AVAILABLE OPTIONS

- Polished chrome finish standard; brushed nickel finish available

LIGHTING SPECIFICATIONS

- Natural-looking LED light color
- CCT: 3,000 Kelvin

SAFETY SPECIFICATIONS

- Entire assembly meets UL/cUL standards

INSTALLATION SPECIFICATIONS

- 120V or 240V electrical connection
- Wall mount model comes ready for hardwire and requires a standard 3.5" or 4" octagonal electrical box
- Controlled by on/off switch on fixture
- Fixture can only be hung in the WxH orientation as shown; fixture is not field-interchangeable



Contour™ Makeup Mirror

Elegant curves and clean lines come together in this striking Contour™. This cool design includes up-and-down tilt, 5X magnification, and a built-in handle to keep the surface smudge free.

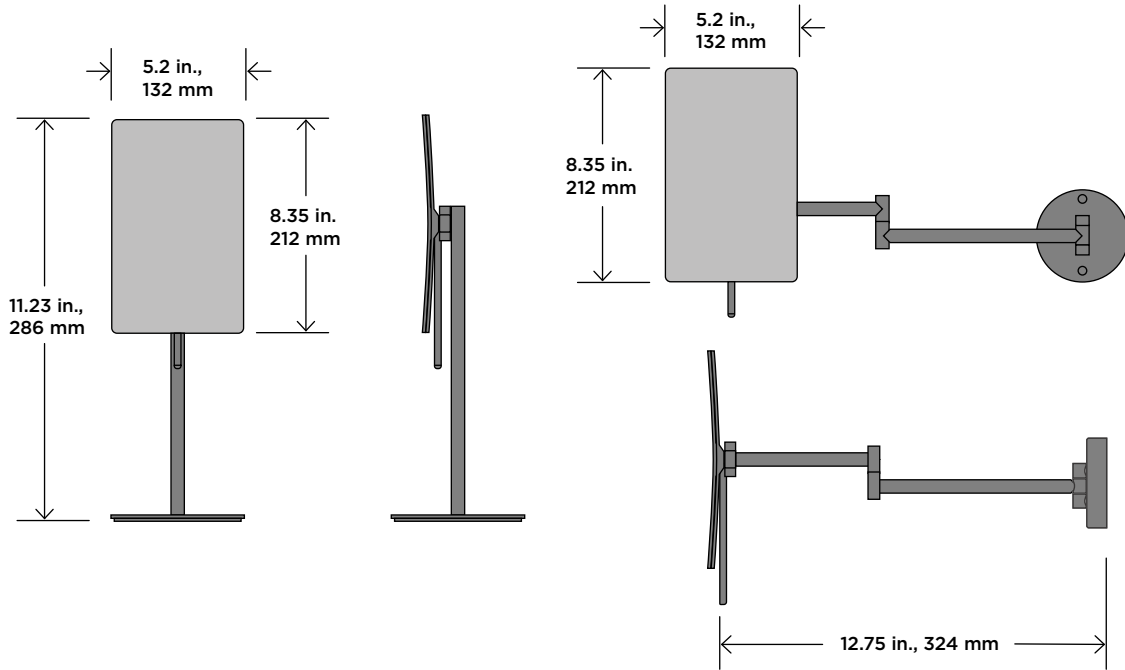

FEATURES AND BENEFITS

- Corrosion-resistant mirror glass
- Integrated tilt handle to keep surface smudge free
- Up-and-down tilt
- Side-to-side swivel (wall mount only)
- 5X magnification
- Suitable for damp bathroom environments
- Easy installation
- 1-year limited warranty
- Designed in America and sourced globally

AVAILABLE OPTIONS

- Polished stainless finish standard, brushed stainless and matte black finishes available^{1, 2}
- Wall mount standard; countertop available

INSTALLATION SPECIFICATIONS

- Fixture can only be hung in the WxH orientation as shown; fixture is not field-interchangeable

¹ Minimum order quantity required.

² May not be available for all configurations.



Elixir™ Makeup Mirror

Take brilliant, natural-looking LED light and mix it together with a bold design and 5X magnification to create an exquisite Elixir™ that's ideal for all things makeup.

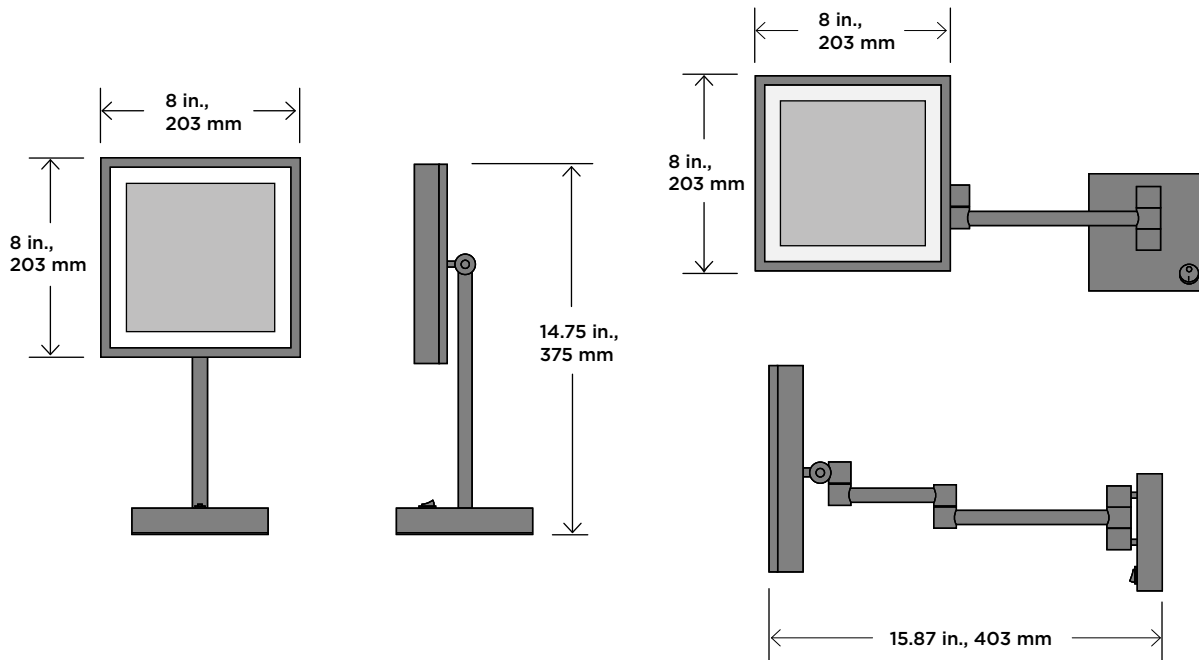

FEATURES AND BENEFITS

- Corrosion-resistant mirror glass
- Forward-facing task lighting
- Up-and-down tilt
- Side-to-side swivel (wall mount only)
- 5X magnification
- Suitable for damp bathroom environments
- Energy efficient
- Easy installation
- 1-year limited warranty
- Designed in America and sourced globally

AVAILABLE OPTIONS

- Polished stainless finish standard, brushed stainless and matte black finishes available^{1,2}
- Hardwired wall mount standard; electrical cord countertop available

LIGHTING SPECIFICATIONS

- Natural-looking LED light color
- CCT: 3,000 Kelvin

SAFETY SPECIFICATIONS

- Entire assembly meets UL/cUL standards

INSTALLATION SPECIFICATIONS

- 120V or 240V electrical connection
- Wall mount model comes ready for hardwire and requires a standard 3.5" or 4" octagonal electrical box
- Countertop model comes with a plug that must be plugged into an outlet
- Controlled by on/off switch on fixture
- Fixture can only be hung in the WxH orientation as shown; fixture is not field-interchangeable

¹ Minimum order quantity required.

² May not be available for all configurations.



Glamour™ Makeup Mirror

The beautiful styling of this contemporary mirror will bring a touch of Glamour™ to your bathroom. It features a halo of natural-looking LED light, up and down tilt, and 5X magnification - perfect for bringing out the glamour in you.

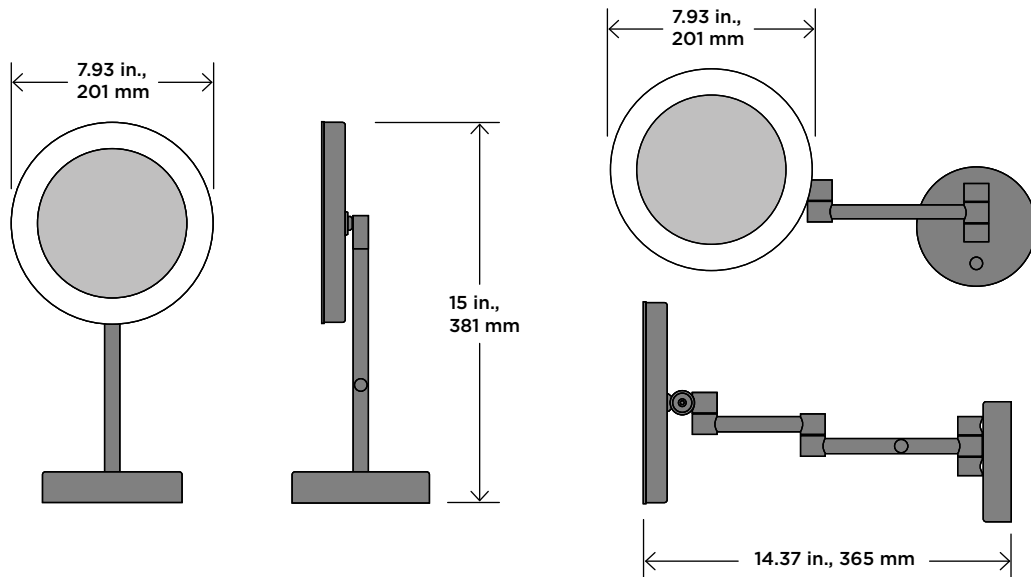

FEATURES AND BENEFITS

- Corrosion-resistant mirror glass
- Forward-facing task lighting
- Up-and-down tilt
- Side-to-side swivel (wall mount only)
- 5X magnification
- Suitable for damp bathroom environments
- Energy efficient
- Easy installation
- 1-year limited warranty
- Designed in America and sourced globally

AVAILABLE OPTIONS

- Polished stainless finish standard, brushed stainless and matte black finishes available^{1,2}
- Hardwired wall mount standard; electrical cord countertop available

LIGHTING SPECIFICATIONS

- Natural-looking LED light color
- CCT: 3,000 Kelvin

SAFETY SPECIFICATIONS

- Entire assembly meets UL/cUL standards

INSTALLATION SPECIFICATIONS

- 120V or 240V electrical connection
- Wall mount model comes ready for hardwire and requires a standard 3.5" or 4" octagonal electrical box
- Countertop model comes with a plug that must be plugged into an outlet
- Controlled by on/off switch on fixture
- Fixture can only be hung in the WxH orientation as shown; fixture is not field-interchangeable

¹ Minimum order quantity required.

² May not be available for all configurations.



Grace™ Makeup Mirror

Purity, simplicity, and elegance are the cornerstones of Grace™. Encompassing up-and-down tilt and 5X magnification, it's a welcome sight for your bathroom.

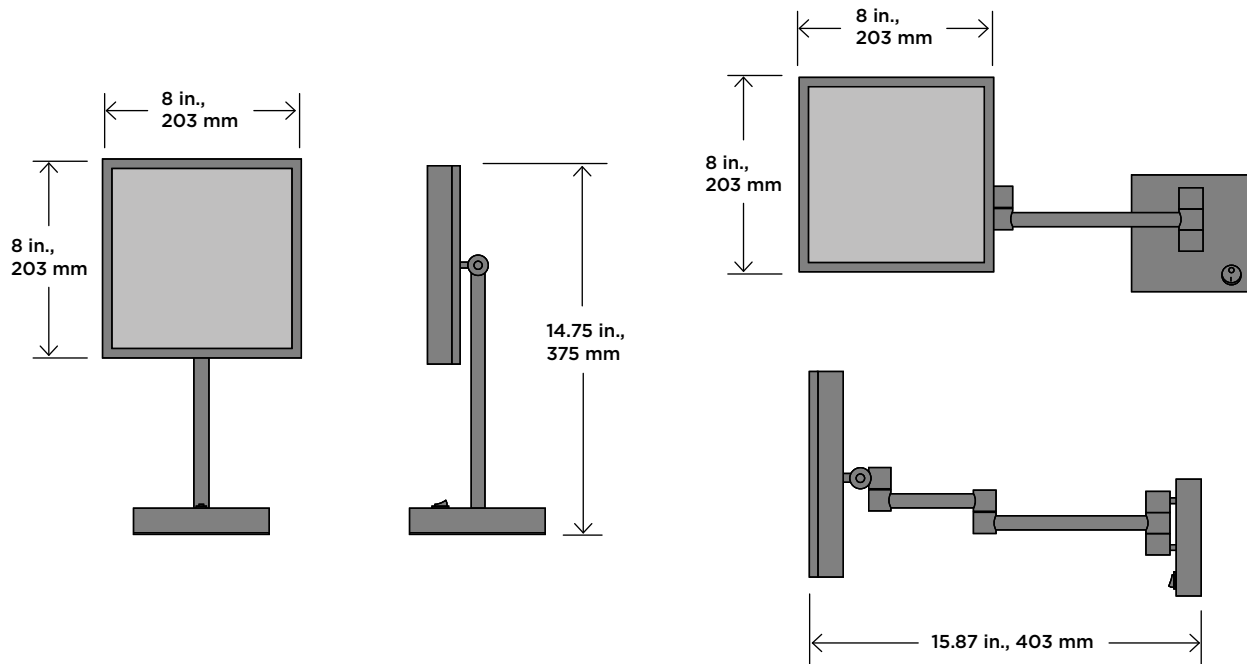

FEATURES AND BENEFITS

- Corrosion-resistant mirror glass
- Up-and-down tilt
- Side-to-side swivel with full pivot (wall mount only)
- 5X magnification
- Suitable for damp bathroom environments
- Easy installation
- 1-year limited warranty
- Designed in America and sourced globally

AVAILABLE OPTIONS

- Polished stainless finish standard, brushed stainless finish available
- Wall mount standard; countertop available

INSTALLATION SPECIFICATIONS

- Fixture can only be hung in the WxH orientation as shown; fixture is not field-interchangeable



Palette™ Makeup Mirror

The right Palette™ is all it takes to consistently look and feel your best. Standing out from the group with dual mirrored surfaces, one with 5X magnification and the other with none, this style of mirror is as chic as it is versatile.

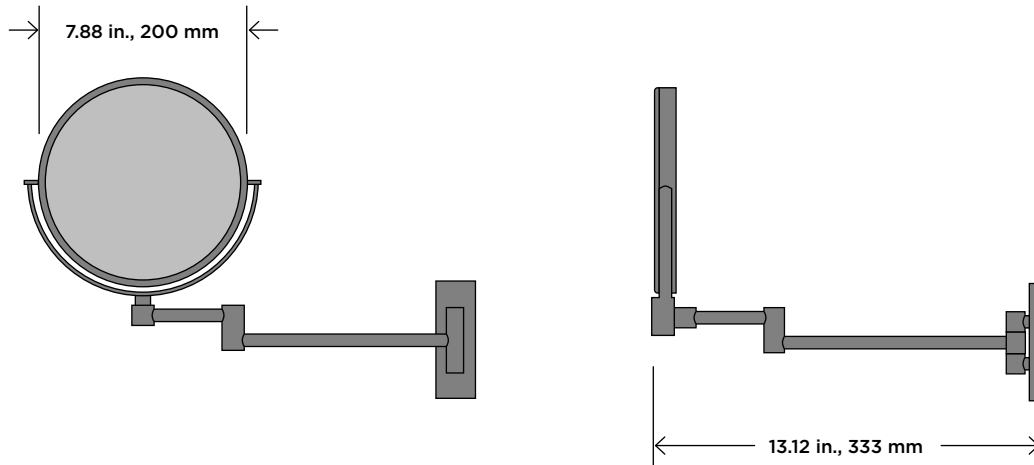

FEATURES AND BENEFITS

- Corrosion-resistant mirror glass
- Up-and-down tilt
- Side-to-side swivel with full pivot
- 5X and 1X magnification
- Wall mount
- Suitable for damp bathroom environments
- Easy installation
- 1-year limited warranty
- Designed in America and sourced globally

AVAILABLE OPTIONS

- Polished stainless finish standard, brushed stainless finish available

INSTALLATION SPECIFICATIONS

- Fixture can only be hung in the WxH orientation as shown; fixture is not field-interchangeable



Splendor™ Makeup Mirror

Bold geometric lines and pure, natural-looking LED light join together to enhance the Splendor™ of your bathroom. With a large mirror face and 5X magnification, makeup application has never been easier.

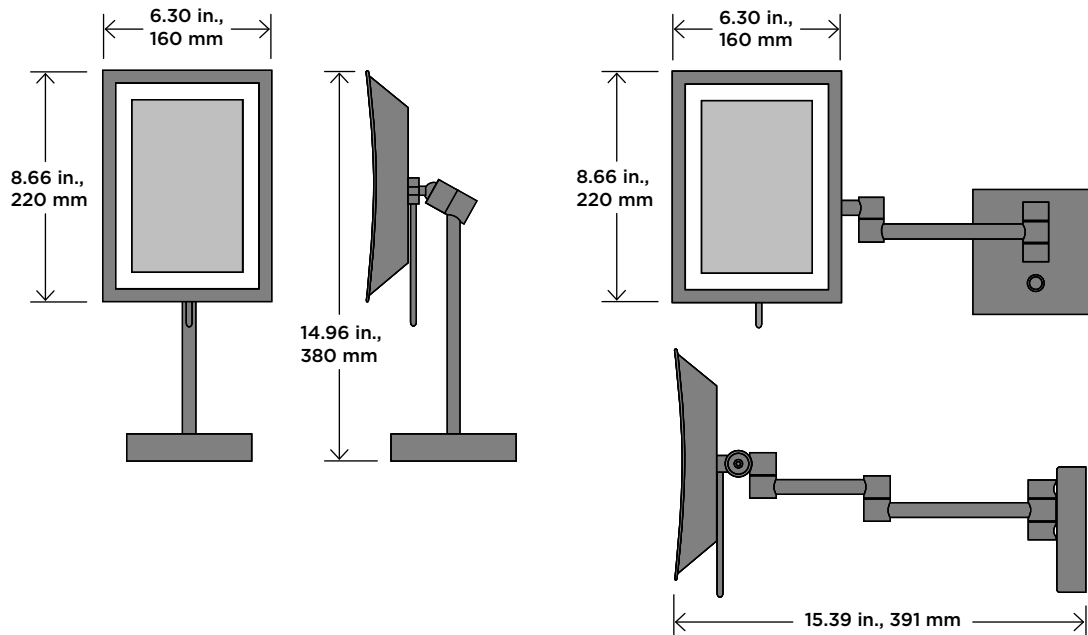

FEATURES AND BENEFITS

- Corrosion-resistant mirror glass
- Forward-facing task lighting
- Integrated tilt handle to keep surface smudge free
- Up-and-down tilt
- Side-to-side swivel (wall mount only)
- 5X magnification
- Suitable for damp bathroom environments
- Energy efficient
- Easy installation
- 1-year limited warranty
- Designed in America and sourced globally

AVAILABLE OPTIONS

- Polished chrome finish standard; brushed nickel finish available
- Hardwired wall mount standard; electrical cord countertop available

LIGHTING SPECIFICATIONS

- Natural-looking LED light color
- CCT: 3,000 Kelvin

SAFETY SPECIFICATIONS

- Entire assembly meets UL/cUL standards

INSTALLATION SPECIFICATIONS

- 120V or 240V electrical connection
- Wall mount model comes ready for hardwire and requires a standard 3.5" or 4" octagonal electrical box
- Countertop model comes with a plug that must be plugged into an outlet
- Controlled by on/off switch on fixture
- Fixture can only be hung in the WxH orientation as shown; fixture is not field-interchangeable





WARDROBE MIRRORS

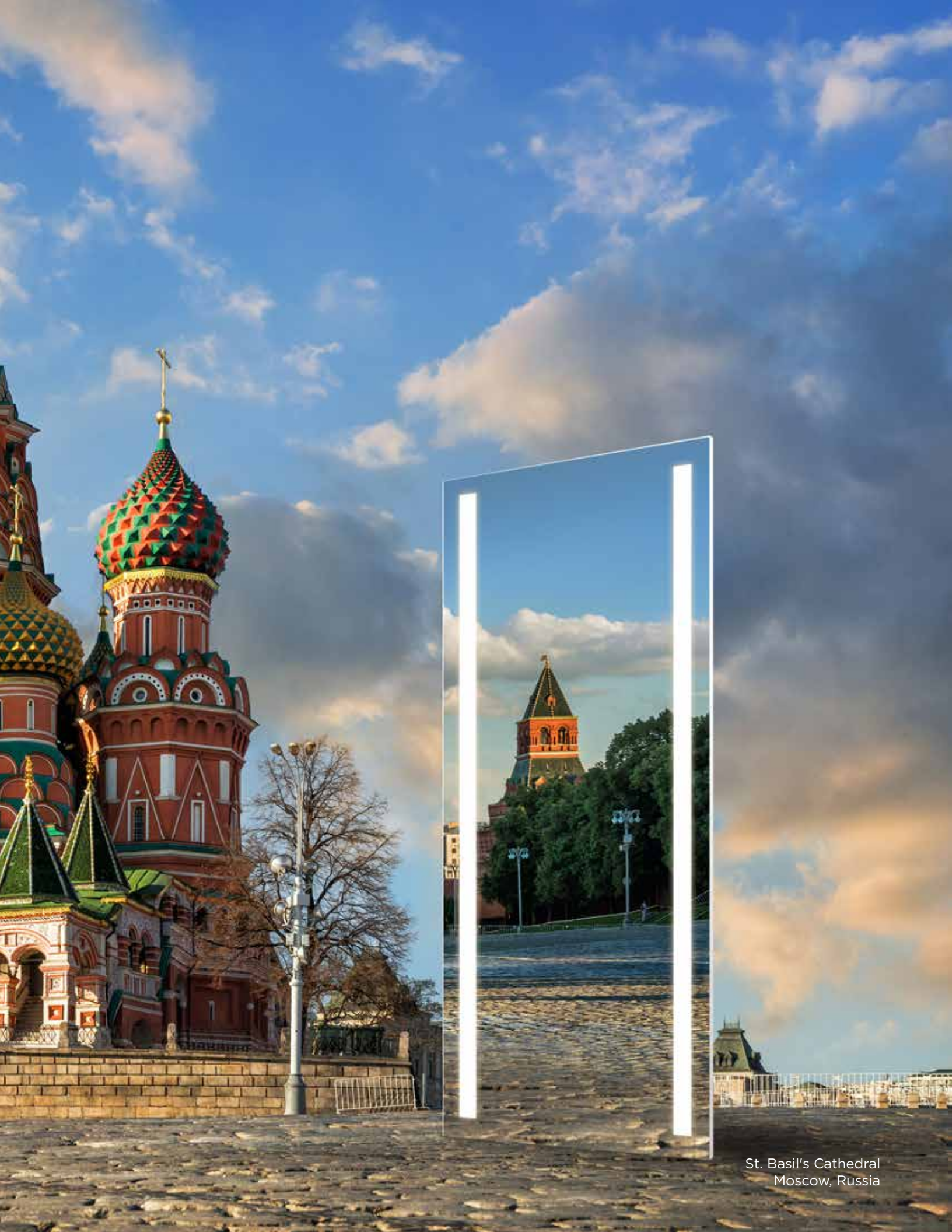

St. Basil's Cathedral
Moscow, Russia

Fusion™ Wardrobe Mirror

The ideal Fusion™ comes from a combination of clean, strong lines and efficient, natural-looking LED lighting — adding a modern statement of prestige while acting as a prominent focal piece for bedrooms, bathrooms, and walk-in closets.

DIMENSIONS

- 26"W x 60"H (660mm x 1524mm)

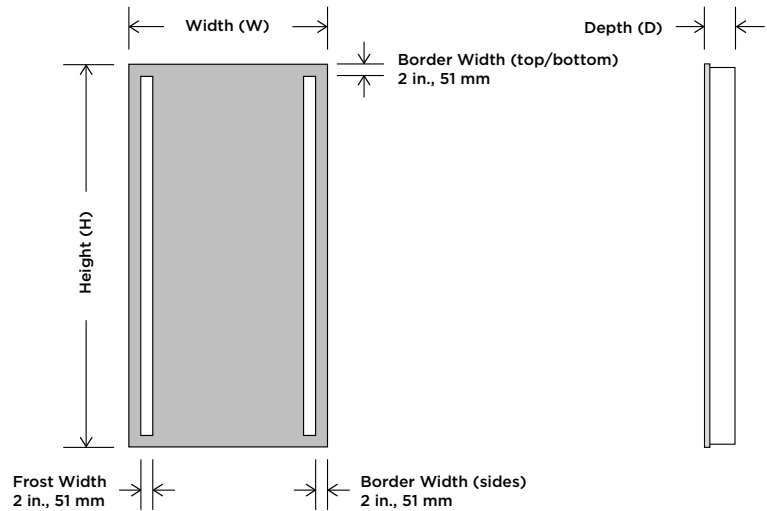

FEATURES AND BENEFITS

- Lead-free, copper-free, corrosion-resistant OmegaMirror™ glass
- Forward-facing task lighting
- Suitable for damp bathroom environments
- Environmentally sustainable
- Energy efficient
- Fast lead times
- Easy installation
- ADA compliant
- Title 24 compliance available
- 10-year limited warranty
- Covered by one or more patents
- Made in America with U.S. and global components

AVAILABLE OPTIONS

- Ava™ Technology^{1,2}
- Keen™ Technology²
- Polaris™ Technology^{1,2}
- Seamless™ Technology^{1,2}
- Vive™ Technology^{1,2}
- Defogger
- CCT: 2,700K
- 0-10V dimming
- Forward-phase dimming
- 277V available³
- Custom sizes

LIGHTING SPECIFICATIONS

- Natural-looking LED light color
- CRI: 90+
- CCT: 3,000 Kelvin
- Replaceable LEDs
- 604 lumens per foot
- Maximum 100 lumens per watt efficacy
- Calculated L₇₀ 52,000-hour LED lifespan

SAFETY SPECIFICATIONS

- Entire assembly meets UL/cUL standards
- International certifications
- Safety-backed mirror

INSTALLATION SPECIFICATIONS

- 120V-240V hardwire electrical connection; provide 36" whip; junction box not required
- Chassis should be mounted to wall studs; mounting holes are provided
- Controlled by non-dimming on/off wall switch
- Installation wiring may be different on mirrors equipped with additional options
- Fixture can only be hung in the WxH orientation as shown; fixture is not field-interchangeable

¹ Minimum order quantity required.

² See technology specification sheets for more details.

³ May not be compatible with all upgrades and options.



Integrity™ Wardrobe Mirror

Add glimmering light and tasteful grace to any space with a powerful impression of Integrity™. Featuring a smooth polished edge and brilliant inner frame of frosted light, this radiant marvel is a welcome addition to entryways, bedrooms and walk-in closets.

DIMENSIONS

- 26"W x 60"H (660mm x 1524mm)

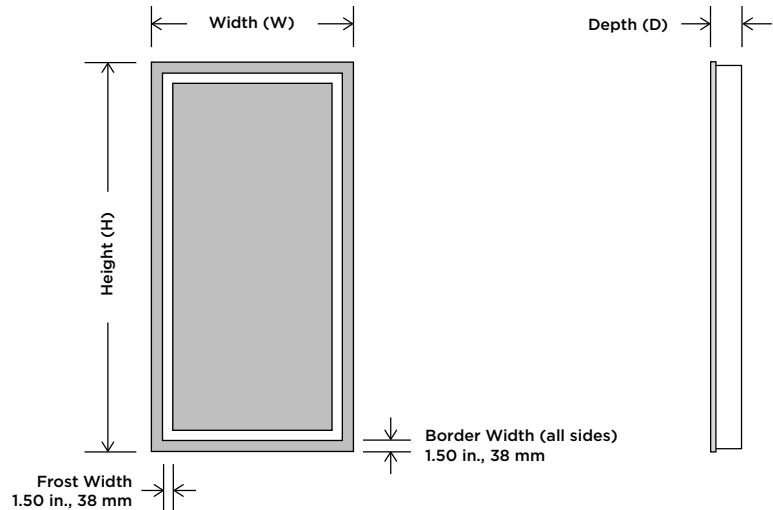

FEATURES AND BENEFITS

- Lead-free, copper-free, corrosion-resistant OmegaMirror™ glass
- Forward-facing task lighting
- Suitable for damp bathroom environments
- Environmentally sustainable
- Energy efficient
- Fast lead times
- Easy installation
- ADA compliant
- Title 24 compliance available
- 10-year limited warranty
- Covered by one or more patents
- Made in America with U.S. and global components

AVAILABLE OPTIONS

- Ava™ Technology^{1,2}
- Keen™ Technology²
- Polaris™ Technology^{1,2}
- Seamless™ Technology^{1,2}
- Vive™ Technology^{1,2}
- Defogger
- CCT: 2,700K
- 0-10V dimming
- Forward-phase dimming
- 277V available³
- Custom sizes

LIGHTING SPECIFICATIONS

- Natural-looking LED light color
- CRI: 90+
- CCT: 3,000 Kelvin
- Replaceable LEDs
- 604 lumens per foot
- Maximum 100 lumens per watt efficacy
- Calculated L₇₀ 52,000-hour LED lifespan

SAFETY SPECIFICATIONS

- Entire assembly meets UL/cUL standards
- International certifications
- Safety-backed mirror

INSTALLATION SPECIFICATIONS

- 120V-240V hardwire electrical connection; provide 36" whip; junction box not required
- Chassis should be mounted to wall studs; mounting holes are provided
- Controlled by non-dimming on/off wall switch
- Installation wiring may be different on mirrors equipped with additional options
- Fixture can only be hung in the WxH orientation as shown; fixture is not field-interchangeable

¹ Minimum order quantity required.

² See technology specification sheets for more details.

³ May not be compatible with all upgrades and options.





FOG-FREE MIRRORS





Niagara Falls
Ontario, Canada

Acclaim™ Fog-Free Mirror

To create our popular Acclaim™, we merged contemporary design, natural-looking LED lighting, and a highly versatile built-in defogger — making shaving easier than ever and revolutionizing how you experience the shower.

DIMENSIONS

- 11.75"W x 11.75"H (298mm x 298mm)
- 11.75"W x 23.75"H (298mm x 603mm)
- 12"W x 28"H (305mm x 711mm)

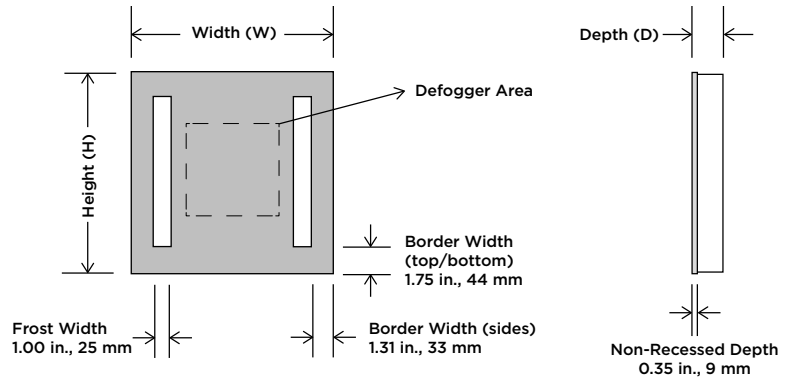

FEATURES AND BENEFITS

- Lead-free, copper-free, corrosion-resistant OmegaMirror™ glass
- Forward-facing task lighting
- Integrated defogger
- Suitable for wet environments, including showers
- Environmentally sustainable
- Energy efficient
- Fast lead times
- ADA compliant
- 3-year limited warranty
- Made in America with U.S. and global components

LIGHTING SPECIFICATIONS

- Natural-looking LED light color
- CRI: 90+
- CCT: 3,000 Kelvin
- 604 lumens per foot
- Maximum 100 lumens per watt efficacy
- Calculated L_{70} 124,000-hour LED lifespan

SAFETY SPECIFICATIONS

- Entire assembly meets UL/cUL standards
- Defogger serves as safety backing
- Low voltage (12V)

INSTALLATION SPECIFICATIONS

- 120V-240V hardwire electrical connection; provide 36" whip; junction box not required
- Chassis should be mounted to wall studs; mounting holes are provided
- Controlled by non-dimming on/off wall switch
- Installation wiring may be different on mirrors equipped with additional options
- Fixture can only be hung in the WxH orientation as shown; fixture is not field-interchangeable



Aqua™ Fog-Free Mirror

Whether it's a quick rinse or a clean morning shave, you'll want to have Aqua™ to do it right. This must-have bathroom companion makes even the simplest shower an experience to behold.

DIMENSIONS

- 11.75"W x 11.75"H (298mm x 298mm)
- 11.75"W x 23.75"H (298mm x 603mm)

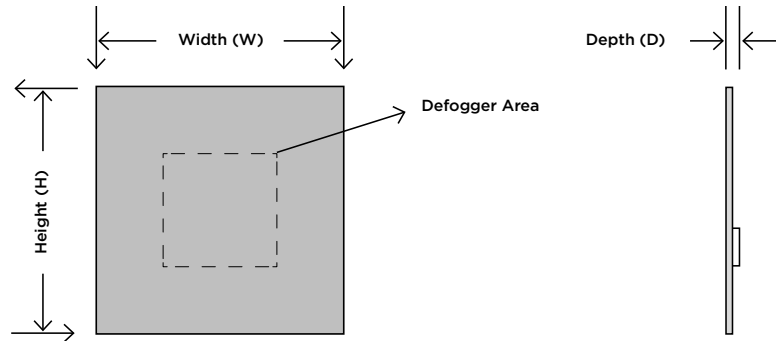

FEATURES AND BENEFITS

- Lead-free, copper-free, corrosion-resistant OmegaMirror™ glass
- Integrated defogger
- Suitable for wet environments, including showers
- Environmentally sustainable
- Fast lead times
- ADA compliant
- 3-year limited warranty
- Made in America with U.S. and global components

SAFETY SPECIFICATIONS

- Defogger serves as safety backing
- Low voltage (12V)

INSTALLATION SPECIFICATIONS

- 120V-240V hardwire electrical connection; transformer must be installed in a dry location, not behind mirror and at least 4 feet from wet environment, but within 25' of mirror
- Defogger controlled by on/off wall switch
- Fixture can only be hung in the WxH orientation as shown; fixture is not field-interchangeable





CORRIDOR LIGHTING



Great Wall of China
Beijing, China

Fifth Avenue™ Corridor Lighting

Your corridors will take on the glamour of Fifth Avenue™ with this stunning and functional lighted mirror scone. Featuring a smooth polished edge with two vertical frames of light, this luminaire is a certain hospitality fashion trend-setter.

DIMENSIONS

- 5"W x 42"H (127mm x 1067mm)

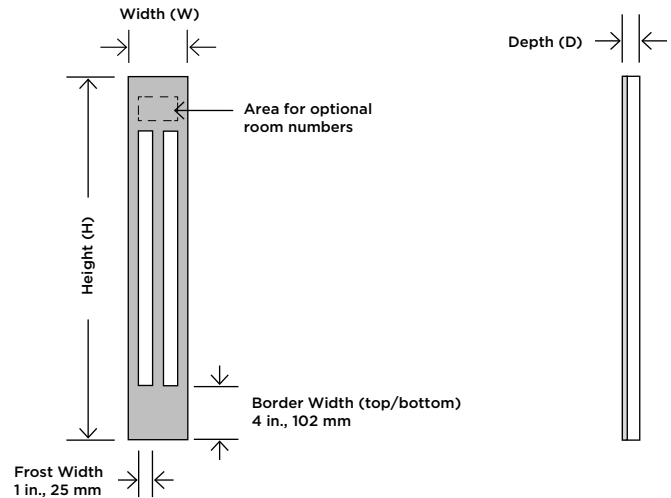

FEATURES AND BENEFITS

- Lead-free, copper-free, corrosion-resistant OmegaMirror™ glass
- Forward-facing lighting
- Environmentally sustainable
- Energy efficient
- Fast lead times
- Easy installation
- 10-year limited warranty
- Made in America with U.S. and global components

AVAILABLE OPTIONS

- Room numbers¹
- Custom sizes available^{1,2}
- 277V available²

LIGHTING SPECIFICATIONS

- Natural-looking LED light color
- CRI: 90+
- CCT: 3,000 Kelvin
- Replaceable LEDs
- 604 lumens per foot
- Maximum 100 lumens per watt efficacy
- Calculated L₇₀ 124,000-hour LED lifespan

SAFETY SPECIFICATIONS

- Entire assembly meets UL/cUL standards
- International certifications
- Safety-backed mirror

INSTALLATION SPECIFICATIONS

- 120V-240V hardwire electrical connection; provide 12" whip; junction box not required
- Chassis should be mounted to wall studs; mounting holes are provided
- Fixture can only be hung in the WxH orientation as shown; fixture is not field-interchangeable

¹ Minimum order quantity required.

² May not be compatible with all upgrades and options.

724



Madison™ Corridor Lighting

Inspired by the boldness of Manhattan’s famous Madison Avenue, this lighted mirror sconce features a robust yet sleek panel of frosted light, illuminating the way to prominence and prestige.

DIMENSIONS

- 5"W x 42"H (127mm x 1067mm)

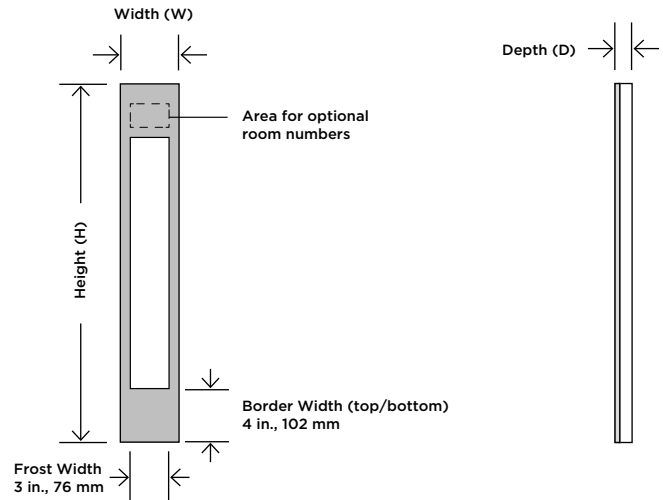

FEATURES AND BENEFITS

- Lead-free, copper-free, corrosion-resistant OmegaMirror™ glass
- Forward-facing lighting
- Environmentally sustainable
- Energy efficient
- Fast lead times
- Easy installation
- 10-year limited warranty
- Made in America with U.S. and global components

AVAILABLE OPTIONS

- Room numbers¹
- Custom sizes available^{1,2}
- 277V available²

LIGHTING SPECIFICATIONS

- Natural-looking LED light color
- CRI: 90+
- CCT: 3,000 Kelvin
- Replaceable LEDs
- 604 lumens per foot
- Maximum 100 lumens per watt efficacy
- Calculated L₇₀ 124,000-hour LED lifespan

SAFETY SPECIFICATIONS

- Entire assembly meets UL/cUL standards
- International certifications
- Safety-backed mirror

INSTALLATION SPECIFICATIONS

- 120V-240V hardwire electrical connection; provide 12" whip; junction box not required
- Chassis should be mounted to wall studs; mounting holes are provided
- Fixture can only be hung in the WxH orientation as shown; fixture is not field-interchangeable

¹ Minimum order quantity required.

² May not be compatible with all upgrades and options.

456



Melrose™ Corridor Lighting

Adventurous and imaginative, the Melrose™ lighted mirror sconce is as energetic as the district for which it's named. Featuring a smooth polished edge with a strip of frosted lights, this sconce is both entertaining and illuminating.

DIMENSIONS

- 5"W x 42"H (127mm x 1067mm)

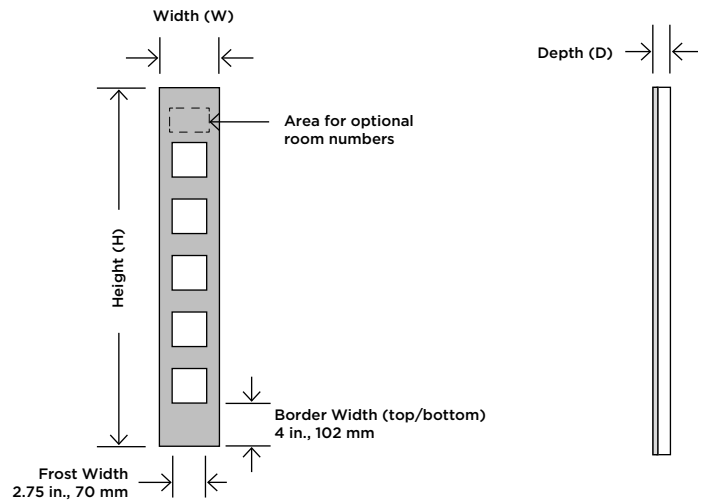

FEATURES AND BENEFITS

- Lead-free, copper-free, corrosion-resistant OmegaMirror™ glass
- Forward-facing lighting
- Environmentally sustainable
- Energy efficient
- Fast lead times
- Easy installation
- 10-year limited warranty
- Made in America with U.S. and global components

AVAILABLE OPTIONS

- Room numbers¹
- Custom sizes available^{1,2}
- 277V available²

LIGHTING SPECIFICATIONS

- Natural-looking LED light color
- CRI: 90+
- CCT: 3,000 Kelvin
- Replaceable LEDs
- 604 lumens per foot
- Maximum 100 lumens per watt efficacy
- Calculated L₇₀ 124,000-hour LED lifespan

SAFETY SPECIFICATIONS

- Entire assembly meets UL/cUL standards
- International certifications
- Safety-backed mirror

INSTALLATION SPECIFICATIONS

- 120V-240V hardwire electrical connection; provide 12" whip; junction box not required
- Chassis should be mounted to wall studs; mounting holes are provided
- Fixture can only be hung in the WxH orientation as shown; fixture is not field-interchangeable

¹ Minimum order quantity required.

² May not be compatible with all upgrades and options.



835

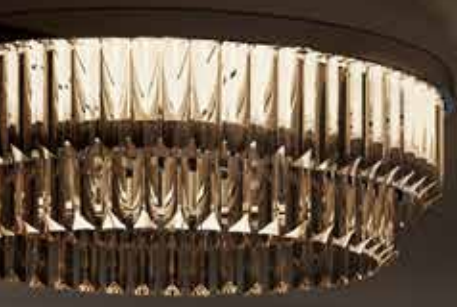

A scenic view of the Toronto skyline across a body of water, featuring the CN Tower and Rogers Centre. The foreground shows a rocky shoreline with some greenery. A semi-transparent grey banner is overlaid across the middle of the image.

FRAMED MIRRORS



CN Tower
Toronto, Ontario

Framed Mirrors

As the world's most experienced provider of high-quality mirrors, we understand many design projects need both lighted mirrors and framed mirrors. That's why in addition to industry-leading lighted mirrors, we also offer an unlimited assortment of non-lit framed mirrors. Whatever your framed mirror needs may be, there isn't a style, size or finish we can't produce¹.



FEATURES AND BENEFITS

- Single-source procurement for lit and non-lit mirrors
- From the world's most experienced mirror company
- Complete customization available
- Unlimited assortment
- Superior quality
- Unmatched workmanship

AVAILABLE OPTIONS

- Metal, wood and polystyrene
- Virtually any profile
- Virtually any texture
- Virtually any color
- Virtually any finish
- Virtually any face width
- Virtually any rabbet size

INSTALLATION SPECIFICATIONS

- Frames come pre-installed on mirrors

¹ Minimum order quantity required.





UVC DISINFECTION



Safeology™
The Science of UV Clean

Safeology™
The Science of UV Clean



Godafoss Waterfall
Northern Iceland

UVC Mobile Air Purifier 700™

The Mobile Air Purifier 700™ leverages the science of UVC light to reduce the airborne spread of viruses¹. Designed for round-the-clock operation, it features proven UVC technology, a powerful centrifugal fan, and a high-grade HEPA filter, and can eliminate up to 99.9% of airborne viruses.

FIXTURE

- Dimensions: 18.5" w x 18.5" d x 47.0" h
- Weight: 175 lbs.
- German-engineered 40,000-hour centrifugal fan and motor
- Quiet operation due to optimized airflow design
- Optimized static pressure performance
- Four 4" multi-directional casters, including a pair of total-lock casters for secure storage
- Durable white powder coated metal construction
- Easy access filter replacement
- Made in America with U.S. and global components

AIRFLOW

- Delivers 6 to 10 Air Changes per Hour (ACH) in 906 ft² and 543 ft² rooms with 9' ceiling, respectively (at turbo speed)²
- Low speed: 15,000 CFH / 250 CFM / 45dB³
- Medium speed: 30,000 CFH / 500 CFM / 52dB
- High speed: 45,000 CFH / 750 CFM / 65dB
- Turbo speed: 48,900 CFH / 815 CFM / 67dB

UVC LAMPING

- Two Philips 60-watt 253.7 nm UVC lamps
- Up to 9,000 hours lamp life at 85% UVC intensity
- No ozone emissions

ELECTRICAL

- 120V AC, 50/60Hz
- Low speed: 324 watts / 2.7 amps
- Medium speed: 384 watts / 3.2 amps
- High speed: 516 watts / 4.3 amps
- Turbo speed: 720 watts / 6.0 amps
- 15' hospital grade three-prong power cord (easily replaceable)⁴
- Master full-power on/off switch
- Control buttons and indicator lights for airflow levels

FILTRATION

- High-grade HEPA filter removes 99.97% of particles $\geq 0.3 \mu\text{m}$ ⁵
- Activated carbon filter with pre-filter increases filter life and reduces airborne odors and chemical disinfectant particulates

TECHNOLOGY⁶

- Imbedded computer for Wi-Fi wireless cloud-based control and monitoring
- UVC lamp remote monitoring
- USB upgradeable software input

SOFTWARE⁶

- Cloud-based back-end management
- Easy wireless provisioning
- Programmable start and stop times
- Remote auto on/off
- Room-based operation validation
- Real-time tracking
- Centralized monitoring and control
- Remote software updates
- Lamp monitoring
- Filter end-of-life monitoring

SAFETY

- Auto off switch for lamp replacement
- Auto off switch for afe filter replacement

¹ UVC light has been proven to inactivate various pathogens; the dosage required may vary by pathogen. The UVC Mobile Air Purifier 1800, a larger version of the 700, has been proven effective at eliminating 99.99% of the airborne SARS-CoV-2 virus that causes COVID-19. Visit www.safeology.com for additional information.

² ACH calculation: CFH / cubic footage of space. Eg. 48,900 CFH / 8,154 ft³ room = 6 ACH.

³ Decibel (dB) comparisons: 40 dB = quiet room in home, refrigerator; 50 dB = private office, moderate rainfall; 60 dB = normal conversation, business office; 70 dB = dishwasher, inside running car.

⁴ Fixture not compatible with Ground-Fault Circuit Interrupter (GFCI) outlet.

⁵ Based on the filter manufacturer's specifications.

⁶ Available with annual service plan, sold separately.



UVC Mobile Air Purifier 1800™

Delivering 6 to 10 air changes per hour, the Mobile Air Purifier 1800™ offers the CDC-recommended standard for effective air cleaning. Designed by lighting technology experts, it harnesses the power of UVC light and HEPA filters to reduce up to 99.9% of viruses in the air¹.

FIXTURE

- Dimensions: 26.0" w x 25.5" d x 48.0" h
- Weight: 265 lbs.
- German-engineered 40,000-hour centrifugal fan and motor
- Quiet operation due to optimized airflow design
- Optimized static pressure performance
- Four 4" multi-directional casters, including a pair of total-lock casters for secure storage
- Durable white powder coated metal construction
- Easy access filter replacement
- Made in America with U.S. and global components

AIRFLOW

- Delivers 6 to 10 Air Changes per Hour (ACH) in 2,000 ft² and 1,200 ft² rooms with 9' ceiling, respectively (at turbo speed)²
- Low speed: 30,000 CFH / 500 CFM / 46dB³
- Medium speed: 60,000 CFH / 1,000 CFM / 58dB
- High speed: 90,000 CFH / 1,500 CFM / 64dB
- Turbo speed: 108,000 CFH / 1,800 CFM / 72dB

UVC LAMPING

- Two Philips 60-watt 253.7 nm UVC lamps
- Up to 9,000 hours lamp life at 85% UVC intensity
- No ozone emissions

ELECTRICAL

- 120V AC, 50/60Hz
- Low speed: 517 watts / 4.4 amps
- Medium speed: 864 watts / 7.4 amps
- High speed: 952 watts / 8.0 amps
- Turbo speed: 1,410 watts / 11.8 amps
- 15' hospital grade three-prong power cord (easily replaceable)⁴
- Master full-power on/off switch
- Control buttons and indicator lights for airflow levels

FILTRATION

- High-grade HEPA filter removes 99.97% of particles $\geq .300 \mu\text{m}$ ⁵
- Activated carbon filter with pre-filter increases filter life and reduces airborne odors and chemical disinfectant particulates

TECHNOLOGY⁶

- Imbedded computer for Wi-Fi wireless cloud-based control and monitoring
- UVC lamp remote monitoring
- USB upgradeable software input

SOFTWARE⁶

- Cloud-based back-end management
- Easy wireless provisioning
- Programmable start and stop times
- Remote auto on/off
- Room-based operation validation
- Real-time tracking
- Centralized monitoring and control
- Remote software updates
- Lamp monitoring
- Filter end-of-life monitoring

SAFETY

- Auto off switch for lamp replacement
- Auto off switch for filter replacement

¹ UVC light has been proven to inactivate various pathogens; the dosage required may vary by pathogen. The UVC Mobile Air Purifier 1800 has been proven effective at eliminating 99.99% of the airborne SARS-CoV-2 virus that causes COVID-19. Visit www.safeology.com for additional information.

² ACH calculation: CFH / cubic footage of space. Eg. 48,900 CFH / 8,154 ft³ room = 6 ACH.

³ Decibel (dB) comparisons: 40 dB = quiet room in home, refrigerator; 50 dB = private office, moderate rainfall; 60 dB = normal conversation, business office; 70 dB = dishwasher, inside running car.

⁴ Fixture not compatible with Ground-Fault Circuit Interrupter (GFCI) outlet.

⁵ Based on the filter manufacturer's specifications.

⁶ Available with annual service plan, sold separately.



UVC Upper Room Linear Recessed Fixture™

The Upper Room Linear Recessed Fixture™ continually disinfects the air, using UVC technology that's been proven to remove up to 99.9% of viruses¹. Providing both an effective way to reduce airborne virus transmission, as well as a sleek, unobtrusive design, it's the ideal product when form and function are of equal importance.

FIXTURE

- Dimensions (visible): 47.00" w x 6.00" d x 1.55" h
- Dimensions (recessed): 47.70" w x 6.75" d x 2.45" h
- Weight: 25 lbs.
- Silent operation
- Easy lamp replacement
- Made in America with U.S. and global components

AIRFLOW

- Single unit is effective for an average 400 ft² / 3,600 ft³ space (20' x 20' x 9')
- UVC dosage calculated upon average air flow in a typical room with HVAC

UVC LAMPING

- Philips 30-watt 253.7 nm UVC lamp
- Up to 9,000 hours lamp life at 85% UVC intensity
- No ozone emissions

ELECTRICAL

- 120-277V AC, 50/60Hz, .25/.10 amps
- 30 watts
- Hard-wired

SAFETY

- Suitable for areas where bottom of fixture can be mounted at least 9'6" above finished floor; fixture may be lowered to 8'10" when opposing wall parallel to light source is less than 25' from fixture. Fixture may be lowered to 8'4" when opposing wall is less than 14.5' from fixture. See Installation and Operation Manual for additional details.
- PIR auto-off sensors to protect against accidental UVC exposure
- Auto-off switch for lamp replacement
- Louvered design for operation in occupied space
- Complies with IEC 62471 Photobiological Safety of Lamps and Lamp Systems

CERTIFICATIONS

- EPA-registered manufacturing facility
- Certified to UL Standards
- Patent pending

SUPPORT

- 3-year warranty
- Field service
- Technical support

¹ UVC light has been proven to inactivate various pathogens; the dosage required may vary by pathogen. Visit www.safeology.com for additional information.



UVC Upper Room Linear Wall Fixture™

Utilizing natural air circulation to move contaminated air into the Upper Room Disinfection Zone, the Upper Room Linear Wall Fixture™ inactivates up to 99.9% of airborne viruses using the proven power of UVC light¹. And with a minimalistic design that makes it barely noticeable, the focus will be on the air, not the fixture.

FIXTURE

- Dimensions: 48.81”w x 7.88”d x 1.63”h
- Weight: 22 lbs.
- Silent operation
- Easy lamp replacement
- Made in America with U.S. and global components

AIRFLOW

- Single unit is effective for an average 400 ft² / 3,600 ft³ space (20’ x 20’ x 9’)
- UVC dosage calculated upon average air flow in a typical room with HVAC

UVC LAMPING

- Philips 40-watt 253.7 nm UVC lamp
- Up to 9,000 hours lamp life at 85% UVC intensity
- No ozone emissions

ELECTRICAL

- 120-277VAC, .33-.14 Amps
- 40 watts
- Hard-wired standard; cord-connect optional

SAFETY

- Suitable for areas where bottom of fixture can be mounted at least 8’10” above finished floor; fixture may be lowered to 8’2” when opposing wall parallel to light source is less than 17’ from fixture. See Installation and Operation Manual for additional details.
- PIR auto-off sensors to protect against accidental UVC exposure
- Auto-off switch for lamp replacement
- Louvered design for operation in occupied space
- Complies with IEC 62471 Photobiological Safety of Lamps and Lamp Systems

CERTIFICATIONS

- EPA-registered manufacturing facility
- Certified to UL Standards
- Patent pending

SUPPORT

- 3-year warranty
- Field service
- Technical support

¹ UVC light has been proven to inactivate various pathogens; the dosage required may vary by pathogen. Visit www.safeology.com for additional information.





NEW PRODUCTS



U.S. Capitol
Washington, D.C.

This page is intentionally left blank, to add new products.

This page is intentionally left blank, to add new products.

This page is intentionally left blank, to add new products.

This page is intentionally left blank, to add new products.

This page is intentionally left blank, to add new products.

This page is intentionally left blank, to add new products.

This page is intentionally left blank, to add new products.

This page is intentionally left blank, to add new products.

This page is intentionally left blank, to add new products.

This page is intentionally left blank, to add new products.

This page is intentionally left blank, to add new products.

This page is intentionally left blank, to add new products.

This page is intentionally left blank, to add new products.

This page is intentionally left blank, to add new products.

This page is intentionally left blank, to add new products.

This page is intentionally left blank, to add new products.

This page is intentionally left blank, to add new products.

This page is intentionally left blank, to add new products.

Information



CONTENTS

242 Client Project Credits

244 Connect with Us

Client Project Credits

Details about the project images featured in this book are listed below.

PG. 14 EXCEPTIONAL STYLE

Product: Custom Eternity Lighted Mirror
Location: Waikiki Beachcomber by
Outrigger, Hawaii
Designer: SFA Design

PG. 16 INNOVATIVE TECHNOLOGY

Product: Custom Mirror TV
Location: Four Seasons, Kuwait
Designer: Yabu Pushelberg

PG. 18 UNPARALLELED VALUE

Product: Custom Silhouette Lighted Mirror
Location: Tulalip Resort Casino, Washington
Designer: IDI Studio

PG. 20 WORLDWIDE APPEAL

Product: Custom Integrity Lighted Mirror
Location: Le Royal Monceau, Paris
Designer: Philippe Starck

PG. 22 UNRIVALED SATISFACTION

Product: Custom Eternity Lighted Mirror
Location: Bellagio Resort, Las Vegas
Designer: The Gettys Group

PG. 28 USA PROJECTS

Product: Custom Element Lighted Mirror
Location: Omni Boston Seaport, Boston
Designer: Waldrop + Nichols Studio

Product: Custom Framed Lighted Mirror
Location: Westin Maui Resort & Spa,
Ka'anapali
Designer: Indidesign

Product: Custom Integrity Lighted Mirror
Location: The Phoenician, Scottsdale
Designer: Wimberly Interiors

PG. 30 NEW YORK PROJECTS

Product: Eternity Lighted Mirror
Location: Shelburne Hotel & Suites
Designer: DiLeonardo

Product: Custom Framed Bela Lighted
Mirror
Location: Canopy by Hilton
Designer: Wilson Associates

Product: Custom Loft Mirror TV
Location: St. Regis Hotel
Designer: HDC Interior Architecture & Design

PG. 32 LAS VEGAS PROJECTS

Product: Custom Silhouette Lighted
Mirror TV
Location: M Resort
Designer: Marnell Corrao Associates

Product: Silhouette Lighted Mirror
Location: Palms Casino
Designer: Avenue Interior Design

Product: Custom Fusion Lighted Mirror
Location: Aria
Designer: BBG-BBGM

PG. 34 CALIFORNIA PROJECTS

Product: Custom Framed Trinity Lighted
Mirror
Location: Le Meridien Arcadia, Los Angeles
Designer: Linda Snyder Associates

Product: Integrity Lighted Mirror
Location: Mandarin Oriental, San Francisco
Designer: BAMO

Product: Silhouette Lighted Mirror TV
Location: Ritz Carlton, Los Angeles
Designer: HBA

PG. 36 CANADA PROJECTS

Product: Custom Stanford Mirror TV
Location: Shangri-La, Vancouver
Designer: James Cheng Architects

Product: Custom Reflection Lighted
Mirror TV
Location: Fairmont Pacific Rim, Vancouver
Designer: Chil Design Group

Product: Custom Framed Novo Lighted
Mirror
Location: Four Seasons, Montreal
Designer: Gilles et Boissier

PG. 38 LATIN AMERICA PROJECTS

Product: Eternity Lighted Mirror
Location: Sandals, Barbados
Designer: Hospitality Purveyors, Inc.

Product: Custom Framed Fusion Lighted
Mirror
Location: Hard Rock Hotel, Los Cabos
Designer: Wimberly Interiors

Product: Custom Integrity Lighted Mirror
Location: Intercontinental Presidente,
Mexico
Designer: Ramos Interiors

PG. 40 EUROPE, AFRICA & OCEANIA PROJECTS

Product: Silhouette Lighted Mirror
Location: Darling at the Star Gold Coast,
Australia
Designer: Bates Smart

Product: Custom Stanford Mirror TV
Location: Waldorf Astoria, Jerusalem
Designer: Metex Design Group

Product: Custom Lighted Mirror TV
Location: Ritz Carlton, Egypt
Designer: Frank Nicholson, Inc.

PG. 42 ASIA & MIDDLE EAST PROJECTS

Product: Custom Fusion Lighted Mirror TV
Location: Four Seasons, Guangzhou
Designer: HBA

Product: Custom Stanford Mirror TV
Location: Four Seasons, Baku
Designer: Richmond International

Product: Custom Quad Fusion Lighted Mirror
Location: Four Seasons, Tokyo
Designer: ILYA Corporation

PG. 44 COMMERCIAL PROJECTS

Product: Integrity Lighted Mirror
Location: O Spa, California
Designer: Designstudio Ltd

Product: Serenity Lighted Mirror
Location: Jacksonville Jaguars, Florida
Designer: Turner Construction

Product: Integrity Lighted Mirror
Location: Arsova Salon, Illinois
Designer: Arsova Salon

PG. 46 MULTI-FAMILY PROJECTS

Product: Custom Quad Fusion Lighted
Mirror TV
Location: One Bal Harbour, Florida
Designer: CMMI

Product: Novo Lighted Mirror
Location: Beverly West Residences, California
Designer: Plum Design West

Product: Custom Integrity Lighted Mirror
Location: One88 Bellevue, Washington
Designer: Graphite Design

PG. 48 HEALTHCARE & SENIOR LIVING PROJECTS

Product: Integrity Lighted Mirror
Location: Martha Jefferson Hospital, Virginia
Designer: Kahler Slater

Product: Trinity Lighted Mirror
Location: Integrative Health & Wellness,
New York
Designer: HOK

Product: Integrity Lighted Mirror
Location: Overlake Hospital, Washington
Designer: NBBJ

PG. 52 CUSTOMIZATION EXPERTISE

Product: Custom Framed Fusion Lighted
Mirror
Location: Inn at the Mission, California
Designer: Kay Lang & Associates

PG. 54 CUSTOM CONCEPTS

Product: Custom Integrity Lighted Mirror
Location: Tameer Tower Model Room, Dubai
Designer: LW Design Group

Product: Custom Framed Integrity Lighted
Mirror
Location: Higgins Hotel, New Orleans
Designer: Kay Lang & Associates

PG. 55 CUSTOM CONCEPTS

Product: Custom Quad Fusion Lighted
Mirror TV
Location: Bal Harbour Hotel, Miami
Designer: CMMI

Product: Custom Novo Lighted Mirror
Location: Four Seasons, India
Designer: Yabu Pushelberg

Product: Custom Silhouette Lighted Mirror
Location: 45 Park Lane Hotel, London
Designer: Thierry W Despont

PG. 56 CUSTOM DESIGNS

Product: Custom Frost Pattern Lighted
Mirror
Location: Sheraton Hotel, Indianapolis
Designer: Remington Hotels

PG. 57 CUSTOM DESIGNS

Product: Custom Frost Pattern Lighted
Mirror
Location: Higgins Hotel, New Orleans
Designer: Kay Lang & Associates

Product: Custom Frost Pattern Lighted
Mirror
Location: Washington Plaza Hotel,
Washington D.C.
Designer: Forrest Perkins

Connect with Us

ON LINE AT WWW.ELECTRICMIRROR.COM AND WWW.SAFEOLGY.COM

Learn about new products and technologies, peruse project photos, review spec sheets and technical documents, download photometric and IES files, confirm patented products, visit our media room, and learn more about Electric Mirror and Safeology.

ON THE PHONE

World Headquarters
United States
+1 425.776.4946

CUSTOMER SUPPORT

If a problem arises with an order after it ships, such as installation or lighting questions, contact Customer Support at customer.support@electricmirror.com or +1 844.264.3217.

Products, product details, technology, and technology details are subject to change without notice. Book content is subject to change without notice. Errors and omissions excepted.

© 2022 Electric Mirror. All rights reserved. Partial or total publication, transmission, copy or other duplication of text, graphics, pictures, etc. in this publication is forbidden without written consent by Electric Mirror.

ELECTRIC MIRROR® is a registered trademark; all rights reserved. 6101 Associated Boulevard, Suite 101, Everett WA 98203.